



**Government of
Jamaica**



IDB
Inter-American
Development Bank

BIDDING DOCUMENTS

Issued: July 26, 2023

for

***Supply, Installation, Commissioning and Maintenance of
CCTV Surveillance System at the Horizon Adult Remand
Correctional Facility***

RFP No: MNS/SSP JA-L1074/2023/07/RFP-001

**Project: *Security Strengthening Project
(4400/OC-JA-L1074)***

Procuring Entity: Ministry of National Security

This Page Intentionally Left Blank

Whenever there is a conflict between the provisions in the Instruction of Bidders (Section I) and the Bidding Data Sheet (Section II), the provisions in the Bidding Data Sheet shall prevail

RE TENDER

Summary

Standard Bidding Documents (SBD) for Procurement of Goods

PART 1 – BIDDING PROCEDURES

Section I. Instructions to Bidders (ITB)

This Section provides information to help Bidders prepare their bids. Information is also provided on the submission, opening, and evaluation of bids and on the award of Contracts. Section I contains provisions that are to be used without modification.

Section II. Bidding Data Sheet (BDS)

This Section includes provisions that are specific to each procurement and that supplement Section I, Instructions to Bidders.

Section III. Evaluation and Qualification Criteria

This Section specifies the criteria to be used to determine the lowest evaluated bid, and the Bidder's qualification requirements to perform the contract.

Section IV. Bidding Forms

This Section includes the forms for the Bid Submission, Price Schedules, Bid Security, and the Manufacturer's Authorization to be submitted with the Bid.

Section V. Eligible Countries

This Section contains information regarding eligible countries.

Section VI. Fraud and Corruption and Prohibited Practices

PART 2 – SUPPLY REQUIREMENTS

Section VII. Schedule of Requirements

This Section includes the List of Goods and Related Services, the Delivery and Completion Schedules, the Technical Specifications and the Drawings that describe the Goods and Related Services to be procured.

PART 3 – CONTRACT

Section VIII. General Conditions of Contract (GCC)

This Section includes the general clauses to be applied in all contracts. The text of the clauses in this Section shall not be modified.

Section IX. Special Conditions of Contract (SCC)

This Section includes clauses specific to each contract that modify or supplement Section VIII, General Conditions of Contract.

Section X: Contract Forms

This Section includes the form for the Agreement, which, once completed, incorporates corrections or modifications to the accepted bid that are permitted under the Instructions to Bidders, the General Conditions of Contract, and the Special Conditions of Contract.

The forms for Performance Security and Advance Payment Security, when required, shall only be completed by the successful Bidder after contract award.

Attachment: Invitation for Bids

An "Invitation for Bids" form is provided at the end of the Bidding Documents for information.

RE TENDERED

Table of Contents

PART 1 BIDDING PROCEDURES 10

SECTION I. INSTRUCTIONS TO BIDDERS 10

A. GENERAL..... 10

1. **Scope of BID..... 10**

2. **Source of Funds..... 10**

3. **Fraud and Corruption and Prohibited Practices..... 10**

4. **Eligible Bidders 10**

5. **Eligible Goods and Related Services 11**

B. CONTENTS OF BIDDING DOCUMENTS 11

6. **Sections of Bidding Documents..... 11**

7. **Clarification of Bidding Documents..... 12**

8. **Amendment of Bidding Documents 12**

C. PREPARATION OF BIDS 13

9. **Cost of Bidding..... 13**

10. **Language of Bid..... 13**

11. **Documents Comprising the Bid 13**

12. **Bid Submission Form and Price Schedules 13**

13. **Alternative Bids 13**

14. **Bid Prices and Discounts 14**

15. **Currencies of Bid..... 15**

16. **Documents Establishing the Eligibility of the Bidder 15**

17. **Documents Establishing the Eligibility of the Goods and Related Services 15**

18. **Documents Establishing the Conformity of the Goods and Related Services 15**

19. **Documents Establishing the Qualifications of the Bidder 16**

20. **Period of Validity of Bids 16**

21. **Bid Security..... 17**

22. **Format and Signing of Bid 18**

D. SUBMISSION AND OPENING OF BIDS 18

23. **Submission, Sealing and Marking of Bids 18**

24. **Deadline for Submission of Bids 19**

25. **Late Bids..... 19**

26. **Withdrawal, Substitution, and Modification of Bids 19**

27.	Bid Opening	19
E.	Evaluation and Comparison of Bids	20
28.	Confidentiality	20
29.	Clarification of Bids	20
30.	Responsiveness of Bids	21
31.	Nonconformities, Errors, and Omissions	21
32.	Preliminary Examination of Bids	22
33.	Examination of Terms and Conditions; Technical Evaluation	22
34.	Conversion to Single Currency	22
35.	Domestic Preference	22
36.	Evaluation of Bids	22
37.	Comparison of Bids	23
38.	Post qualification of the Bidder	23
39.	Purchaser’s Right to Accept Any Bid, and to Reject Any or All Bids	24
F.	Award of Contract	24
40.	Award Criteria	24
41.	Purchaser’s Right to Vary Quantities at Time of Award	24
42.	Notification of Award	24
43.	Signing of Contract	25
44.	Performance Security	25
	Section II. Bidding Data Sheet	26
	SECTION III. EVALUATION AND QUALIFICATION CRITERIA	31
1.1.	Overall Evaluation Process	32
1.1.1.	Eligibility Requirements	32
1.1.2.	Detailed Evaluation	32
	SECTION IV. BIDDING FORMS	39
	Section IV. Bidding Forms	40
	Bidder Information Form	40
	Joint Venture Partner Information Form	41
	Bid Submission Form	42
	PRICE SCHEDULE FORMS	44
	Price Schedule: Goods Manufactured Outside the Purchaser’s Country, to be Imported	44
	Price Schedule: Goods Manufactured Outside the Purchaser’s Country, already imported	45

Price Schedule: Goods Manufactured in the Purchaser’s Country	46
Price and Completion Schedule - Related Services	47
Bid Security Form	48
Form of Bid Security	50
Bid-Securing Declaration	50
Manufacturer’s Authorization	52
SECTION V. ELIGIBLE COUNTRIES	54
SECTION VI. PROHIBITED PRACTICES	56
PART II. SUPPLY REQUIREMENTS	Error! Bookmark not defined.
SECTION VII. SCHEDULE OF REQUIREMENTS	60
Implementation Objective	Error! Bookmark not defined.
Duration	Error! Bookmark not defined.
List of Goods and Delivery Schedule	101
List of Related Services and Completion Schedule	102
PART III CONTRACT	103
SECTION VIII. GENERAL CONDITIONS OF CONTRACT	103
1. Definitions	103
2. Contract Documents	104
3. Fraud and Corruption and Prohibited Practices	104
4. Interpretation	104
5. Language	105
6. Joint Venture, Consortium or Association	105
7. Eligibility	105
8. Notices	106
9. Governing Law	106
10. Settlement of Disputes	106
11. Inspections and Audit by the Bank	106
12. Scope of Supply	107
13. Delivery of Documents	107
14. Supplier’s Responsibilities	107
15. Contract Price	107
16. Terms of Payment	107
17. Taxes and Duties	108
18. Performance Security	108

19. Copyright	108
20. Confidential Information	108
21. Subcontracting	109
22. Specifications and Standards	109
23. Packing and Documents	110
24. Insurance	110
25. Transportation	110
26. Inspections and Tests	110
27. Liquidated Damages	111
28. Warranty	111
29. Patent Indemnity	112
30. Limitation of Liability	113
31. Changes in Laws and Regulations	113
32. Force Majeure	113
33. Change Orders and Contract Amendments	114
34. Extension of Time	114
35. Termination	115
36. Assignment	115
37. Export Restriction	116
Section IX. Special Conditions of Contract	117
Attachment 1: Price Adjustment Formula	122
Attachment 2: Fraud and Corruption and Prohibited Practices	124
Section X. Contract Forms	130
Letter of Acceptance	130
Contract Agreement	131
Performance Security	133
<i>Note: *[Information for the Executing Agency: Article 15 (a) states: "Requirements for Demand: (a) A demand under the guarantee shall be supported by such other documents as the guarantee specifies, and in any event by a statement, by the beneficiary, indicating in what respect the applicant is in breach of its obligations under the underlying relationship. This statement may be in the demand or in a separate document accompanying or identifying the demand.]</i>	
Advance Payment Security	133
SAMPLE FORMAT: Invitation for Bids	134

PART 1 BIDDING PROCEDURES

SECTION I. INSTRUCTIONS TO BIDDERS

A. GENERAL

1. Scope of BID

- 1.1 The Purchaser indicated in the Bidding Data Sheet (BDS), issues these Bidding Documents for the supply of Goods and Related Services incidental thereto as specified in Section VII, Schedule of Requirements. The name and identification number of this International Competitive Bidding (ICB) procurement are specified in the BDS. The name, identification, and number of lots of are provided in the BDS.
- 1.2 Throughout these Bidding Documents:
 - (a) the term “in writing” means communicated in written form (e.g. by mail, e-mail, fax, telex) with proof of receipt;
 - (b) if the context so requires, “singular” means “plural” and vice versa; and
 - (c) “day” means calendar day.

2. Source of Funds

- 2.1 The Borrower or Recipient (hereinafter called “Borrower”) **specified in the BDS** has applied for or received financing (hereinafter called “funds”) from the Inter-American Development Bank (hereinafter called “the Bank”) toward the cost of the project **named in the BDS**. The Borrower intends to apply a portion of the funds to eligible payments under the contract for which these Bidding Documents are issued.
- 2.2 Payments by the Bank will be made only at the request of the Borrower and upon approval by the Bank in accordance with the terms and conditions of the financing agreement between the Borrower and the Bank (hereinafter called the Loan Contract), and will be subject in all respects to the terms and conditions of that Loan Contract. No party other than the Borrower shall derive any rights from the Loan Contract or have any claim to the funds.

3. Fraud and Corruption and Prohibited Practices

- 3.1 The Bank requires compliance with its policy in regard to fraud and corruption and prohibited practices as set forth in Section VI.

4. Eligible Bidders

- 4.1 A Bidder, and all parties constituting the Bidder, shall be nationals from member countries of the Bank. Bidders from other countries shall be disqualified from participating in contracts intended to be financed in whole or in part from Bank loans. Section V of this document establishes the Bank’s member countries, as well as the criteria to determine the nationality of the Bidders and the country of origin of goods and services. The Bidders with the nationality of a Bank’s member country and the goods to be supplied under the Contract are not eligible if:
 - (a) as a matter of law or official regulation, the Borrower’s country prohibits commercial relations with that country; or

- (b) by an act of compliance with a decision of the United Nations Security Council taken under Chapter VII of the Charter of the United Nations, the Borrower's Country prohibits any imports of goods from that country or any payments to persons or entities in that country.
- 4.2 A Bidder shall not have a conflict of interest. All Bidders found to have conflict of interest shall be disqualified. Bidders may be considered to have a conflict of interest with one or more parties in this bidding process, if they:
- (a) are or have been associated in the past, with a firm or any of its affiliates which have been engaged by the Purchaser to provide consulting services for the preparation of the design, specifications, and other documents to be used for the procurement of the goods to be purchased under these Bidding Documents; or
 - (b) submit more than one bid in this bidding process, except for alternative offers permitted under ITB Clause 13. However, this does not limit the participation of subcontractors in more than one bid;
- 4.3 A Bidder, parent company, subsidiary, or previous form of organization constituted by or with any of the same individual(s) as principal(s), declared ineligible to be awarded a contract by the Bank or by another International Financial Institution (IFI) with which the Bank may have entered into an agreement for the mutual enforcement of sanctions, and is that is under a declaration of ineligibility during the period of time established by the Bank in accordance with ITB Clause 3, at the date of contract award, shall be disqualified.
- 4.4 Government-owned enterprises in the Borrower's Country shall be eligible only if they can establish that they (i) are legally and financially autonomous, (ii) operate under commercial law, and (iii) are not a dependent agency of the Purchaser.
- 4.5 Bidders shall provide such evidence of their continued eligibility satisfactory to the Purchaser, as the Purchaser shall reasonably request.

5. Eligible Goods and Related Services

- 5.1 All the Goods and Related Services to be supplied under the Contract and financed by the Bank shall have their origin in any Bank's member country in accordance with Section V, Eligible Countries, except in the case indicated in Clause 4.1 (i) y (ii).
- 5.2 For purposes of this Clause, the term "goods" includes commodities, raw material, machinery, equipment, and industrial plants; and "related services" includes services such as insurance, transportation, installation, commissioning, training, and initial maintenance.
- 5.3 The criteria to determine the origin of the goods and services has been established in the Section V. Eligible Countries.

B. CONTENTS OF BIDDING DOCUMENTS

6. Sections of Bidding Documents

- 6.1 The Bidding Documents consist of Parts 1, 2, and 3, which include all the Sections indicated below, and should be read in conjunction with any Addendum issued in accordance with ITB Clause 8.

PART 1 Bidding Procedures

Section I. Instructions to Bidders (ITB)

Section II. Bidding Data Sheet (BDS)

Section III. Evaluation and Qualification Criteria

Section IV. Bidding Forms

Section V. Eligible Countries

Section VI. Fraud and Corruption and Prohibited Practices

PART 2 Supply Requirements

Section VII. Schedule of Requirements

PART 3 Contract

Section VIII. General Conditions of Contract (GCC)

Section IX. Special Conditions of Contract (SCC)

Section X. Contract Forms

- 6.2 The Invitation for Bids issued by the Purchaser is not part of the Bidding Documents.
- 6.3 The Purchaser is not responsible for the completeness of the Bidding Documents and their addendum, if they were not obtained directly from the Purchaser.
- 6.4 The Bidder is expected to examine all instructions, forms, terms, and specifications in the Bidding Documents. Failure to furnish all information or documentation required by the Bidding Documents may result in the rejection of the bid.

7. Clarification of Bidding Documents

- 7.1 A prospective Bidder requiring any clarification of the Bidding Documents shall contact the Purchaser in writing at the Purchaser's address **specified in the BDS**. The Purchaser will respond in writing to any request for clarification, provided that such request is received no later than twenty-one (21) days prior to the deadline for submission of bids. The Purchaser shall forward copies of its response to all those who have acquired the Bidding Documents directly from it, including a description of the inquiry but without identifying its source. Should the Purchaser deem it necessary to amend the Bidding Documents as a result of a clarification, it shall do so following the procedure under ITB Clause 8 and ITB Sub-Clause 24.2.

8. Amendment of Bidding Documents

- 8.1 At any time prior to the deadline for submission of bids, the Purchaser may amend the Bidding Documents by issuing addendum.
- 8.2 Any addendum issued shall be part of the Bidding Documents and shall be communicated in writing to all who have obtained the Bidding Documents directly from the Purchaser.
- 8.3 To give prospective Bidders reasonable time in which to take an addendum into account in preparing their bids, the Purchaser may, at its discretion, extend the deadline for the submission of bids, pursuant to ITB Sub-Clause 24.2.

C. PREPARATION OF BIDS

9. Cost of Bidding

9.1 The Bidder shall bear all costs associated with the preparation and submission of its bid, and the Purchaser shall not be responsible or liable for those costs, regardless of the conduct or outcome of the bidding process.

10. Language of Bid

10.1 The Bid, as well as all correspondence and documents relating to the bid exchanged by the Bidder and the Purchaser, shall be written in the language specified in the BDS. Supporting documents and printed literature that are part of the Bid may be in another language provided they are accompanied by an accurate translation of the relevant passages into the language specified in the BDS, in which case, for purposes of interpretation of the Bid, such translation shall govern.

11. Documents Comprising the Bid

11.1 The Bid shall comprise the following:

- (a) Bid Submission Form and the applicable Price Schedules, in accordance with ITB Clauses 12, 14, and 15;
- (b) Bid Security or Bid-Securing Declaration, in accordance with ITB Clause 21, if required;
- (c) written confirmation authorizing the signatory of the Bid to commit the Bidder, in accordance with ITB Clause 22;
- (d) documentary evidence in accordance with ITB Clause 16 establishing the Bidder's eligibility to bid;
- (e) documentary evidence in accordance with ITB Clause 17, that the Goods and Related Services to be supplied by the Bidder are of eligible origin;
- (f) documentary evidence in accordance with ITB Clauses 18 and 30, that the Goods and Related Services conform to the Bidding Documents;
- (g) documentary evidence in accordance with ITB Clause 19 establishing the Bidder's qualifications to perform the contract if its bid is accepted; and
- (h) any other document required in the BDS.

12. Bid Submission Form and Price Schedules

12.1 The Bidder shall submit the Bid Submission Form using the form furnished in Section IV, Bidding Forms. This form must be completed without any alterations to its format, and no substitutes shall be accepted. All blank spaces shall be filled in with the information requested.

12.2 The Bidder shall submit the Price Schedules for Goods and Related Services, according to their origin as appropriate, using the forms furnished in Section IV, Bidding Forms.

13. Alternative Bids

13.1 Unless otherwise **specified in the BDS**, alternative bids shall not be considered.

14. Bid Prices and Discounts

- 14.1 The prices and discounts quoted by the Bidder in the Bid Submission Form and in the Price Schedules shall conform to the requirements specified below.
- 14.2 All lots and items must be listed and priced separately in the Price Schedules.
- 14.3 The price to be quoted in the Bid Submission Form shall be the total price of the bid, excluding any discounts offered.
- 14.4 The Bidder shall quote any unconditional discounts and indicate the method for their application in the Bid Submission Form.
- 14.5 The terms CIP, FCA, CPT and other similar terms shall be governed by the rules prescribed in the current edition of Incoterms, published by The International Chamber of Commerce, as specified in the BDS.
- 14.6 Prices shall be quoted as specified in each Price Schedule included in Section IV, Bidding Forms. The dis-aggregation of price components is required solely for the purpose of facilitating the comparison of bids by the Purchaser. This shall not in any way limit the Purchaser's right to contract on any of the terms offered. In quoting prices, the Bidder shall be free to use transportation through carriers registered in any eligible country, in accordance with Section V Eligible Countries. Similarly, the Bidder may obtain insurance services from any eligible country in accordance with Section V Eligible Countries. Prices shall be entered in the following manner:
- (a) For Goods of origin in the Purchaser's Country:
 - (i) the price of the Goods quoted CIP (named place of destination), in the Purchaser's country as specified in the BDS, including all customs duties and sales and other taxes already paid or payable on the components and raw material used in the manufacture or assembly of the Goods;
 - (ii) any Purchaser's Country sales tax and other taxes which will be payable on the Goods if the contract is awarded to the Bidder; and
 - (b) For Goods of origin outside the Purchaser's Country, to be imported:
 - (i) the price of the Goods, quoted CIP (named place of destination), in the Purchaser's Country, as specified in the BDS;
 - (ii) in addition to the CIP prices specified in (b)(i) above, the price of the Goods to be imported may be quoted FCA (named place of destination) or CPT (named place), if so specified in the BDS;
 - (c) For Goods of origin outside the Purchaser's Country, already imported:
 - (i) the price of the Goods, quoted CIP (named place of destination), in the Purchaser's country, including the original import value of the Goods; plus any mark-up (or rebate); plus any other related local cost, and custom duties and other import taxes already paid or to be paid on the Goods already imported.
 - (ii) the custom duties and other import taxes already paid (need to be supported with documentary evidence) or to be paid on the Goods already imported;
 - (iii) the price of the Goods, quoted in CIP (named place of destination), in the Purchaser's country, excluding the custom duties and other import taxes

already paid or to be paid on the Goods already imported that is obtained as the difference between (i) and (ii) above;

(iv) any Purchaser's Country sales and other taxes which will be payable on the Goods if the contract is awarded to the Bidder; and

(d) for Related Services, other than inland transportation and other services required to convey the Goods to their final destination, whenever such Related Services are specified in the Schedule of Requirements:

(i) the price of each item comprising the Related Services (inclusive of any applicable taxes).

14.7 Prices quoted by the Bidder shall be fixed during the Bidder's performance of the Contract and not subject to variation on any account, unless otherwise specified in the BDS. A Bid submitted with an adjustable price quotation shall be treated as non responsive and shall be rejected, pursuant to ITB Clause 30. However, if in accordance with the BDS, prices quoted by the Bidder shall be subject to adjustment during the performance of the Contract, a bid submitted with a fixed price quotation shall not be rejected, but the price adjustment shall be treated as zero.

14.8 If so indicated in ITB Sub-Clause 1.1, bids are being invited for individual contracts (lots) or for any combination of contracts (packages). Unless otherwise indicated in the BDS, prices quoted shall correspond to 100 % of the items specified for each lot and to 100% of the quantities specified for each item of a lot. Bidders wishing to offer any price reduction (discount) for the award of more than one Contract shall specify the applicable price reduction in accordance with ITB Sub-Clause 14.4 provided the bids for all lots are submitted and opened at the same time.

15. Currencies of Bid

15.1 The Bidder shall quote in the currency of the Purchaser's Country the portion of the bid price that corresponds to expenditures incurred in the currency of the Purchaser's country, unless otherwise specified in the BDS.

15.2 The Bidder may express the bid price in the currency of any fully convertible currency. If the Bidder wishes to be paid in a combination of amounts in different currencies, it may quote its price accordingly but shall use no more than three currencies in addition to the currency of the Purchaser's Country.

16. Documents Establishing the Eligibility of the Bidder

16.1 To establish their eligibility in accordance with ITB Clause 4, Bidders shall complete the Bid Submission Form, included in Section IV, Bidding Forms.

17. Documents Establishing the Eligibility of the Goods and Related Services

17.1 To establish the eligibility of the Goods and Related Services in accordance with ITB Clause 5, Bidders shall complete the country of origin declarations in the Price Schedule Forms, included in Section IV, Bidding Forms.

18. Documents Establishing the Conformity of the Goods and Related Services

18.1 To establish the conformity of the Goods and Related Services to the Bidding Documents, the Bidder shall furnish as part of its Bid the documentary evidence that

the Goods conform to the technical specifications and standards specified in Section VII, Schedule of Requirements.

- 18.2 The documentary evidence may be in the form of literature, drawings or data, and shall consist of a detailed item by item description of the essential technical and performance characteristics of the Goods and Related Services, demonstrating substantial responsiveness of the Goods and Related Services to the technical specification, and if applicable, a statement of deviations and exceptions to the provisions of the Schedule of Requirements.
- 18.3 The Bidder shall also furnish a list giving full particulars, including available sources and current prices of spare parts, special tools, etc., necessary for the proper and continuing functioning of the Goods during the period specified in the BDS following commencement of the use of the goods by the Purchaser.
- 18.4 Standards for workmanship, process, material, and equipment, as well as references to brand names or catalogue numbers specified by the Purchaser in the Schedule of Requirements, are intended to be descriptive only and not restrictive. The Bidder may offer other standards of quality, brand names, and/or catalogue numbers, provided that it demonstrates, to the Purchaser's satisfaction, that the substitutions ensure substantial equivalence or are superior to those specified in the Schedule of Requirements.

19. Documents Establishing the Qualifications of the Bidder

- 19.1 The documentary evidence of the Bidder's qualifications to perform the contract if its bid is accepted shall establish to the Purchaser's satisfaction:
- (a) that, if required in the BDS, a Bidder that does not manufacture or produce the Goods it offers to supply shall submit the Manufacturer's Authorization using the form included in Section IV, Bidding Forms to demonstrate that it has been duly authorized by the manufacturer or producer of the Goods to supply these Goods in the Purchaser's Country;
 - (b) that, if required in the BDS, in case of a Bidder not doing business within the Purchaser's Country, the Bidder is or will be (if awarded the contract) represented by an Agent in the country equipped and able to carry out the Supplier's maintenance, repair and spare parts-stocking obligations prescribed in the Conditions of Contract and/or Technical Specifications; and
 - (c) that the Bidder meets each of the qualification criterion specified in Section III, Evaluation and Qualification Criteria.

20. Period of Validity of Bids

- 20.1 Bids shall remain valid for the period specified in the BDS after the bid submission deadline date prescribed by the Purchaser. A bid valid for a shorter period shall be rejected by the Purchaser as non-responsive.
- 20.2 In exceptional circumstances, prior to the expiration of the bid validity period, the Purchaser may request bidders to extend the period of validity of their bids. The request and the responses shall be made in writing. If a Bid Security is requested in accordance with ITB Clause 21, it shall also be extended for a corresponding period. A Bidder may refuse the request without forfeiting its Bid Security. A Bidder granting

the request shall not be required or permitted to modify its bid, except as provided in ITB Sub-Clause 20.3.

- 20.3 In the case of fixed price contracts, if the award is delayed by a period exceeding fifty-six (56) days beyond the expiry of the initial bid validity, the Contract price shall be adjusted as specified in the request for extension. Bid evaluation shall be based on the Bid Price without taking into consideration the above correction.

21. Bid Security

- 21.1 The Bidder shall furnish as part of its bid, a Bid Security or a Bid-Securing Declaration, if required, as specified in the BDS.
- 21.2 The Bid Security shall be in the amount specified in the BDS and denominated in the currency of the Purchaser's Country or a freely convertible currency, and shall:
- (a) at the bidder's option, be in the form of either a letter of credit, or a bank guarantee from a banking institution, or a bond issued by a surety;
 - (b) be issued by a reputable institution selected by the bidder and located in any eligible country. If the institution issuing the bond is located outside the Purchaser's Country, it shall have a correspondent financial institution located in the Purchaser's Country to make it enforceable.
 - (c) be substantially in accordance with one of the forms of Bid Security included in Section IV, Bidding Forms, or other form approved by the Purchaser prior to bid submission;
 - (d) be payable promptly upon written demand by the Purchaser in case the conditions listed in ITB Clause 21.5 are invoked;
 - (e) be submitted in its original form; copies will not be accepted;
 - (f) remain valid for a period of 28 days beyond the validity period of the bids, as extended, if applicable, in accordance with ITB Clause 20.2;
- 21.3 If a Bid Security or a Bid-Securing Declaration is required in accordance with ITB Sub-Clause 21.1, any bid not accompanied by a substantially responsive Bid Security or Bid Securing Declaration in accordance with ITB Sub-Clause 21.1, shall be rejected by the Purchaser as non-responsive.
- 21.4 The Bid Security of unsuccessful Bidders shall be returned as promptly as possible upon the successful Bidder's furnishing of the Performance Security pursuant to ITB Clause 44.
- 21.5 The Bid Security may be forfeited or the Bid Securing Declaration executed:
- (a) if a Bidder withdraws its bid during the period of bid validity specified by the Bidder on the Bid Submission Form, except as provided in ITB Sub-Clause 20.2; or
 - (b) if the successful Bidder fails to:
 - (i) sign the Contract in accordance with ITB Clause 43;
 - (ii) furnish a Performance Security in accordance with ITB Clause 44.
- 21.6 The Bid Security or Bid Securing Declaration of a JV must be in the name of the JV that submits the bid. If the JV has not been legally constituted at the time of bidding, the Bid Security or Bid-Securing Declaration shall be in the names of all future

partners as named in the letter of intent mentioned in Section IV “Bidding Forms,” Bidder Information Form Item 7.

- 21.7 21.7 If a bid security is **not required in the BDS**, and
- (a) if a Bidder withdraws its bid during the period of bid validity specified by the Bidder on the Letter of Bid Form, except as provided in ITB 20.2, or
 - (b) if the successful Bidder fails to: sign the Contract in accordance with ITB 43; or furnish a performance security in accordance with ITB 44;
- the Borrower may, **if provided for in the BDS**, declare the Bidder disqualified to be awarded a contract by the Purchaser for a period of time **as stated in the BDS**.

22. Format and Signing of Bid

- 22.1 The Bidder shall prepare one original of the documents comprising the bid as described in ITB Clause 11 and clearly mark it “ORIGINAL.” In addition, the Bidder shall submit copies of the bid, in the number specified in the **BDS** and clearly mark them “COPY.” In the event of any discrepancy between the original and the copies, the original shall prevail.
- 22.2 The original and all copies of the bid shall be typed or written in indelible ink and shall be signed by a person duly authorized to sign on behalf of the Bidder.
- 22.3 Any interlineation, erasures, or overwriting shall be valid only if they are signed or initialed by the person signing the Bid.

D. SUBMISSION AND OPENING OF BIDS

23. Submission, Sealing and Marking of Bids

- 23.1 Bidders may always submit their bids by mail or by hand. When so specified in the **BDS**, bidders shall have the option of submitting their bids electronically.
 - (a) Bidders submitting bids by mail or by hand, shall enclose the original and each copy of the Bid, including alternative bids, if permitted in accordance with ITB Clause 13, in separate sealed envelopes, duly marking the envelopes as “Original” and “Copy.” These envelopes containing the original and the copies shall then be enclosed in one single envelope. The rest of the procedure shall be in accordance with ITB sub-Clauses 23.2 and 23.3.
 - (b) Bidders submitting bids electronically shall follow the electronic bid submission procedures specified in the BDS.
- 23.2 The inner and outer envelopes shall:
 - (a) Bear the name and address of the Bidder;
 - (b) be addressed to the Purchaser in accordance with ITB Sub-Clause 24.1;
 - (c) bear the specific identification of this bidding process indicated in ITB 1.1 and any additional identification marks as specified in the BDS; and
 - (d) bear a warning not to open before the time and date for bid opening, in accordance with ITB Sub-Clause 27.1.
- 23.3 If all envelopes are not sealed and marked as required, the Purchaser will assume no responsibility for the misplacement or premature opening of the bid.

24. Deadline for Submission of Bids

- 24.1 Bids must be received by the Purchaser at the address and no later than the date and time specified in the BDS.
- 24.2 The Purchaser may, at its discretion, extend the deadline for the submission of bids by amending the Bidding Documents in accordance with ITB Clause 8, in which case all rights and obligations of the Purchaser and Bidders previously subject to the deadline shall thereafter be subject to the deadline as extended.

25. Late Bids

- 25.1 The Purchaser shall not consider any bid that arrives after the deadline for submission of bids, in accordance with ITB Clause 24. Any bid received by the Purchaser after the deadline for submission of bids shall be declared late, rejected, and returned unopened to the Bidder.

26. Withdrawal, Substitution, and Modification of Bids

- 26.1 A Bidder may withdraw, substitute, or modify its Bid after it has been submitted by sending a written notice in accordance with ITB Clause 23, duly signed by an authorized representative, and shall include a copy of the authorization (the power of attorney) in accordance with ITB Sub-Clause 22.2, (except that no copies of the withdrawal notice are required). The corresponding substitution or modification of the bid must accompany the respective written notice. All notices must be:
 - (a) submitted in accordance with ITB Clauses 22 and 23 (except that withdrawal notices do not require copies), and in addition, the respective envelopes shall be clearly marked “Withdrawal,” “Substitution,” or “Modification;” and
 - (b) received by the Purchaser prior to the deadline prescribed for submission of bids, in accordance with ITB Clause 24.
- 26.2 Bids requested to be withdrawn in accordance with ITB Sub-Clause 26.1 shall be returned unopened to the Bidders.
- 26.3 No bid may be withdrawn, substituted, or modified in the interval between the deadline for submission of bids and the expiration of the period of bid validity specified by the Bidder on the Bid Submission Form or any extension thereof.

27. Bid Opening

- 27.1 The Purchaser shall conduct the bid opening in public at the address, date and time specified in the BDS. Any specific electronic bid opening procedures required if electronic bidding is permitted in accordance with ITB Sub-Clause 23.1, shall be as specified in the BDS.
- 27.2 First, envelopes marked “WITHDRAWAL” shall be opened and read out and the envelope with the corresponding bid shall not be opened, but returned to the Bidder. If the withdrawal envelope does not contain a copy of the “power of attorney” confirming the signature as a person duly authorized to sign on behalf of the Bidder, the corresponding bid will be opened. No bid withdrawal shall be permitted unless the corresponding withdrawal notice contains a valid authorization to request the withdrawal and is read out at bid opening. Next, envelopes marked “SUBSTITUTION” shall be opened and read out and exchanged with the

corresponding Bid being substituted, and the substituted Bid shall not be opened, but returned to the Bidder. No Bid substitution shall be permitted unless the corresponding substitution notice contains a valid authorization to request the substitution and is read out at bid opening. Envelopes marked “MODIFICATION” shall be opened and read out with the corresponding Bid. No Bid modification shall be permitted unless the corresponding modification notice contains a valid authorization to request the modification and is read out at Bid opening. Only envelopes that are opened and read out at Bid opening shall be considered further.

- 27.3 All other envelopes shall be opened one at a time, reading out: the name of the Bidder and whether there is a modification; the Bid Prices, including any discounts and alternative offers; the presence of a Bid Security or Bid-Securing Declaration, if required; and any other details as the Purchaser may consider appropriate. Only discounts and alternative offers read out at Bid opening shall be considered for evaluation. No Bid shall be rejected at Bid opening except for late bids, in accordance with ITB Sub-Clause 25.1.
- 27.4 The Purchaser shall prepare a record of the Bid opening that shall include, as a minimum: the name of the Bidder and whether there is a withdrawal, substitution, or modification; the Bid Price, per lot if applicable, including any discounts, and alternative offers if they were permitted; and the presence or absence of a Bid Security or Bid-Securing Declaration, if one was required. The Bidders’ representatives who are present shall be requested to sign the attendance sheet. A copy of the record shall be distributed to all Bidders who submitted bids in time, and posted online when electronic bidding is permitted.

E. Evaluation and Comparison of Bids

28. Confidentiality

- 28.1 Information relating to the examination, evaluation, comparison, and post qualification of bids, and recommendation of contract award, shall not be disclosed to bidders or any other persons not officially concerned with such process until publication of the Contract Award.
- 28.2 Any effort by a Bidder to influence the Purchaser in the examination, evaluation, comparison, and post qualification of the bids or contract award decisions may result in the rejection of its Bid.
- 28.3 Notwithstanding ITB Sub-Clause 28.2, from the time of bid opening to the time of Contract Award, if any Bidder wishes to contact the Purchaser on any matter related to the bidding process, it should do so in writing.

29. Clarification of Bids

- 29.1 To assist in the examination, evaluation, comparison and post-qualification of the bids, the Purchaser may, at its discretion, ask any Bidder for a clarification of its Bid. Any clarification submitted by a Bidder in respect to its Bid and that is not in response to a request by the Purchaser shall not be considered. The Purchaser’s request for clarification and the response shall be in writing. No change in the prices or substance of the Bid shall be sought, offered, or permitted, except to confirm the correction of

arithmetic errors discovered by the Purchaser in the Evaluation of the bids, in accordance with ITB Clause 31.

30. Responsiveness of Bids

- 30.1 The Purchaser's determination of a bid's responsiveness is to be based on the contents of the bid itself.
- 30.2 A substantially responsive Bid is one that conforms to all the terms, conditions, and specifications of the Bidding Documents without material deviation, reservation, or omission. A material deviation, reservation, or omission is one that:
- (a) affects in any substantial way the scope, quality, or performance of the Goods and Related Services specified in the Contract; or
 - (b) limits in any substantial way, inconsistent with the Bidding Documents, the Purchaser's rights or the Bidder's obligations under the Contract; or
 - (c) if rectified would unfairly affect the competitive position of other bidders presenting substantially responsive bids.
- 30.3 If a bid is not substantially responsive to the Bidding Documents, it shall be rejected by the Purchaser and may not subsequently be made responsive by the Bidder by correction of the material deviation, reservation, or omission.

31. Nonconformities, Errors, and Omissions

- 31.1 Provided that a Bid is substantially responsive, the Purchaser may waive any non-conformities or omissions in the Bid that do not constitute a material deviation.
- 31.2 Provided that a bid is substantially responsive, the Purchaser may request that the Bidder submit the necessary information or documentation, within a reasonable period of time, to rectify nonmaterial nonconformities or omissions in the bid related to documentation requirements. Such omission shall not be related to any aspect of the price of the Bid. Failure of the Bidder to comply with the request may result in the rejection of its Bid.
- 31.3 Provided that the Bid is substantially responsive, the Purchaser shall correct arithmetical errors on the following basis:
- (a) if there is a discrepancy between the unit price and the line item total that is obtained by multiplying the unit price by the quantity, the unit price shall prevail and the line item total shall be corrected, unless in the opinion of the Purchaser there is an obvious misplacement of the decimal point in the unit price, in which case the line item total as quoted shall govern and the unit price shall be corrected;
 - (b) if there is an error in a total corresponding to the addition or subtraction of subtotals, the subtotals shall prevail and the total shall be corrected; and
 - (c) if there is a discrepancy between words and figures, the amount in words shall prevail, unless the amount expressed in words is related to an arithmetic error, in which case the amount in figures shall prevail subject to (a) and (b) above.
- 31.4 If the Bidder that submitted the lowest evaluated Bid does not accept the correction of errors, its Bid shall be rejected.

32. Preliminary Examination of Bids

- 32.1 The Purchaser shall examine the bids to confirm that all documents and technical documentation requested in ITB Clause 11 have been provided, and to determine the completeness of each document submitted.
- 32.2 The Purchaser shall confirm that the following documents and information have been provided in the Bid. If any of these documents or information is missing, the offer shall be rejected.
 - (a) Bid Submission Form, in accordance with ITB Sub-Clause 12.1;
 - (b) Price Schedules, in accordance with ITB Sub-Clause 12.2;
 - (c) Bid Security or Bid Securing Declaration, in accordance with ITB Clause 21, if applicable.

33. Examination of Terms and Conditions; Technical Evaluation

- 33.1 The Purchaser shall examine the Bid to confirm that all terms and conditions specified in the GCC and the SCC have been accepted by the Bidder without any material deviation or reservation.
- 33.2 The Purchaser shall evaluate the technical aspects of the Bid submitted in accordance with ITB Clause 18, to confirm that all requirements specified in Section VII, Schedule of Requirements of the Bidding Documents have been met without any material deviation or reservation.
- 33.3 If, after the examination of the terms and conditions and the technical evaluation, the Purchaser determines that the Bid is not substantially responsive in accordance with ITB Clause 30, it shall reject the Bid.

34. Conversion to Single Currency

- 34.1 For evaluation and comparison purposes, the Purchaser shall convert all bid prices expressed in amounts in various currencies into an amount in a single currency **specified in the BDS**, using the selling exchange rates established by the source and on the date **specified in the BDS**.

35. Domestic Preference

- 35.1 Domestic preference shall not be a factor in bid evaluation, unless otherwise specified in the BDS.

36. Evaluation of Bids

- 36.1 The Purchaser shall evaluate each bid that has been determined, up to this stage of the evaluation, to be substantially responsive.
- 36.2 To evaluate a Bid, the Purchaser shall only use all the factors, methodologies and criteria defined in ITB Clause 36. No other criteria or methodology shall be permitted.
- 36.3 To evaluate a Bid, the Purchaser shall consider the following:
 - (a) evaluation will be done for Items or Lots, as specified in the BDS; and the Bid Price as quoted in accordance with clause 14;

- (b) price adjustment for correction of arithmetic errors in accordance with ITB Sub-Clause 31.3;
 - (c) price adjustment due to discounts offered in accordance with ITB Sub-Clause 14.4;
 - (d) adjustments due to the application of the evaluation criteria specified in the BDS from amongst those set out in Section III, Evaluation and Qualification Criteria;
 - (e) adjustments due to the application of a margin of preference, in accordance with ITB Clause 35 if applicable.
- 36.4 The Purchaser's evaluation of a bid will exclude and not take into account:
- (a) In the case of Goods manufactured in the Purchaser's Country, sales and other similar taxes, which will be payable on the goods if a contract is awarded to the Bidder;
 - (b) in the case of Goods manufactured outside the Purchaser's Country, already imported or to be imported, customs duties and other import taxes levied on the imported Good, sales and other similar taxes, which will be payable on the Goods if the contract is awarded to the Bidder;
 - (c) any allowance for price adjustment during the period of execution of the contract, if provided in the bid.
- 36.5 The Purchaser's evaluation of a bid may require the consideration of other factors, in addition to the Bid Price quoted in accordance with ITB Clause 14. These factors may be related to the characteristics, performance, and terms and conditions of purchase of the Goods and Related Services. The effect of the factors selected, if any, shall be expressed in monetary terms to facilitate comparison of bids, unless otherwise specified in Section III, Evaluation and Qualification Criteria. The factors, methodologies and criteria to be used shall be as specified in ITB 36.3 (d).
- 36.6 If so **specified in the BDS**, these Bidding Documents shall allow Bidders to quote separate prices for one or more lots, and shall allow the Purchaser to award one or multiple lots to more than one Bidder. The methodology of evaluation to determine the lowest-evaluated lot combinations, is specified in Section III, Evaluation and Qualification Criteria.

37. Comparison of Bids

- 37.1 The Purchaser shall compare all substantially responsive bids to determine the lowest-evaluated bid, in accordance with ITB Clause 36.

38. Post qualification of the Bidder

- 38.1 The Purchaser shall determine to its satisfaction whether the Bidder that is selected as having submitted the lowest evaluated and substantially responsive bid is qualified to perform the Contract satisfactorily.
- 38.2 The determination shall be based upon an examination of the documentary evidence of the Bidder's qualifications submitted by the Bidder, pursuant to ITB Clause 19.
- 38.3 An affirmative determination shall be a prerequisite for award of the Contract to the Bidder. A negative determination shall result in disqualification of the bid, in which

event the Purchaser shall proceed to the next lowest evaluated bid to make a similar determination of that Bidder's capabilities to perform satisfactorily.

39. Purchaser's Right to Accept Any Bid, and to Reject Any or All Bids

- 39.1 The Purchaser reserves the right to accept or reject any bid, and to annul the bidding process and reject all bids at any time prior to contract award, without thereby incurring any liability to Bidders.

F. Award of Contract

40. Award Criteria

- 40.1 The Purchaser shall award the Contract to the Bidder whose offer has been determined to be the lowest evaluated bid and is substantially responsive to the Bidding Documents, provided further that the Bidder is determined to be qualified to perform the Contract satisfactorily.

41. Purchaser's Right to Vary Quantities at Time of Award

- 41.1 At the time the Contract is awarded, the Purchaser reserves the right to increase or decrease the quantity of Goods and Related Services originally specified in Section VII, Schedule of Requirements, provided this does not exceed the percentages **specified in the BDS**, and without any change in the unit prices or other terms and conditions of the bid and the Bidding Documents.

42. Notification of Award

- 42.1 Prior to the expiration of the period of bid validity, the Purchaser shall notify the successful Bidder, in writing, that its Bid has been accepted.
- 42.2 Until a formal Contract is prepared and executed, the notification of award shall constitute a binding Contract.
- 42.3 The Purchaser shall publish in UNDB online and in the Bank's website the results identifying the bid and lot numbers and the following information: (i) name of each Bidder who submitted a Bid; (ii) bid prices as read out at bid opening; (iii) name and evaluated prices of each Bid that was evaluated; (iv) name of bidders whose bids were rejected and the reasons for their rejection; and (v) name of the winning Bidder, and the price it offered, as well as the duration and summary scope of the contract awarded. After publication of the award, unsuccessful bidders may request in writing to the Purchaser for a debriefing seeking explanations on the grounds on which their bids were not selected. The Purchaser shall promptly respond in writing to any unsuccessful Bidder who, after Publication of contract award, requests a debriefing.
- 42.4 Upon the successful Bidder's furnishing of the signed Contract Form and performance security pursuant to ITB Clause 44, the Purchaser will promptly notify each unsuccessful Bidder and will discharge its bid security, pursuant to ITB Clause 21.4.

43. Signing of Contract

- 43.1 Promptly after notification, the Purchaser shall send the successful Bidder the Agreement and the Special Conditions of Contract.
- 43.2 Within twenty-eight (28) days of receipt of the Agreement, the successful Bidder shall sign, date, and return it to the Purchaser.
- 43.3 Notwithstanding ITB 43.2 above, in case signing of the Contract Agreement is prevented by any export restrictions attributable to the Purchaser, to the country of the Purchaser, or to the use of the products/goods, systems or services to be supplied, where such export restrictions arise from trade regulations from a country supplying those products/goods, systems or services, the Bidder shall not be bound by its bid, always provided, always provided, however, that the Bidder can demonstrate to the satisfaction of the Purchaser and of the Bank that signing of the Contact Agreement has not been prevented by any lack of diligence on the part of the Bidder in completing any formalities, including applying for permits, authorizations and licenses necessary for the export of the products/goods, systems or services under the terms of the Contract.

44. Performance Security

- 44.1 Within twenty eight (28) days of the receipt of notification of award from the Purchaser, the successful Bidder, if required, shall furnish the Performance Security in accordance with the GCC, using for that purpose the Performance Security Form included in Section X Contract forms, or another Form acceptable to the Purchaser. The Purchaser shall promptly notify the name of the winning Bidder to each unsuccessful Bidder and discharge the Bid Securities of the unsuccessful bidders pursuant to ITB Sub-Clause 21.4.
- 44.2 Failure of the successful Bidder to submit the above-mentioned Performance Security or sign the Contract shall constitute sufficient grounds for the annulment of the award and forfeiture of the Bid Security or execution of the Bid-Securing Declaration. In that event the Purchaser may award the Contract to the next lowest evaluated Bidder, whose offer is substantially responsive and is determined by the Purchaser to be qualified to perform the Contract satisfactorily.

Section II. Bidding Data Sheet

The following specific data for the goods to be procured shall complement, supplement, or amend the provisions in the Instructions to Bidders (ITB). Whenever there is a conflict, the provisions herein shall prevail over those in ITB.

ITB Clause Reference	A. General
ITB 1.1	The Purchaser is: Ministry of National Security
ITB 1.1	<p>The name and identification number of the ICB are:</p> <p><i>Supply, Installation, Commissioning and Maintenance of CCTV Surveillance System at the Horizon Adult Remand Correctional Facility</i> <i>RFP No: MNS/SSP JA-L1074/2023/07/RFP-001</i></p>
ITB 2.1	The Borrower is: <i>Government of Jamaica</i>
ITB 2.1	The name of the Project is: <i>Security Strengthening Project (SSP)</i>
ITB 4.1	A Bidder, and all parties constituting the Bidder, shall be nationals from member countries of the Inter-American Development Bank.
ITB 4.5	<p>Bidders shall submit a valid Public Procurement Commission (PPC) registration certificate upon bid submission. The required PPC category is <i>Safety and Security Services</i>.</p> <p>Bidders shall submit to the Procuring Entity a valid Tax Compliance Letter (TCL) upon bid submission.</p>
ITB 5.1	All the Goods and Related Services to be supplied under the Contract and financed by the Bank shall have their origin in any Bank's member country.
	B. Contents of Bidding Documents
ITB 7.1	<p>ALL CLARIFICATIONS SHOULD BE DONE THROUGH THE ELECTRONIC GOVERNMENT PROCUREMENT SYSTEM (www.gojep.gov.jm).</p> <p>For assistance in regards to registration, training, access to tender document and upload of bid proposals please contact the Ministry of Finance, Office of Public Procurement Policy Customer Service Desk at: (876) 932-5220, 932-5246,932-5253/932-5251/932-5244.</p> <p>AT THE FIRST SIGN OF ANY TECHNICAL DIFFICULTIES, BIDDERS MUST MAKE CONTACT WITH THE MINISTRY OF FINANCE VIA THE CONTACT NUMBERS LISTED ABOVE.</p> <p>Alternatively, if there are challenges accessing the e-GP system, clarification can be sent to:</p>

	<p>Attention: Procurement Specialist Address: Ministry of National Security Security Strengthening Project Shops 31-32 Kingston Mall Kingston, Jamaica W.I.</p> <p>Telephone: (876) 469-4723 Electronic mail address: <i>sspprocurement@mns.gov.jm</i> E-mail Subject: <i>Supply, Installation, Commissioning and Maintenance of CCTV Surveillance System at the Horizon Adult Remand Correctional Facility-RFP No: MNS/SSP JA-L1074/2023/07/RFP-001</i></p> <p><u>NB: Emails should only be used as SECONDARY method of clarification.</u> The deadline for the receipt of clarifications is: September 4, 2023 at 5:00 pm.</p>
	C. Preparation of Bids
ITB 10.1	The language of the bid is: <i>English.</i>
ITB 11.1 (h)	<p>The Bidder shall submit the following additional documents along with those outlined in ITB 11.1 (h) above:</p> <ol style="list-style-type: none"> <i>1. Three (3) references as proof of implementation of a project of similar size and nature within the last eight (8) years</i> <i>2. Relevant Experience</i> <i>3. All appropriate Bid Forms as detailed in Section IV of this document;</i> <i>4. Detailed response to the requirements specified in this document;</i> <i>5. Completed Specifications Forms with the specifications being proposed for each item</i> <p><i>All other required documentation to support your proposal.</i></p>
ITB 13.1	Alternative Bids <i>shall not be</i> considered.
ITB 14.5	The Incoterms edition is: <i>Incoterms 2020</i>
ITB 14.6 (a)(i), (b)(i) and (c)(iii)	Place of Destination: <i>DDP Kingston</i>
ITB 14.6 (b) (ii)	<i>Not Applicable, only DDP price to be quoted.</i>
ITB 14.7	The prices quoted by the Bidder <i>shall not</i> be adjustable. If prices shall be adjustable, the methodology is specified in Section III Evaluation and Qualification Criteria.

ITB 14.8	Prices quoted for each lot shall correspond at least to 100 % of the items specified for each lot. Prices quoted for each item of a lot shall correspond at least to 100 % of the quantities specified for this item of a lot.
ITB 15.1	The Bidder <i>is not</i> required to quote in the currency of the Purchaser's Country the portion of the bid price that corresponds to expenditures incurred in that currency.
ITB 18.3	Period of time the Goods are expected to be functioning (for the purpose of spare parts): Twenty-four (24) Months
ITB 19.1 (a)	Manufacturer's authorization is: Required
ITB 19.1 (b)	After sales service is: Required
ITB 20.1	The bid validity period shall be 150 days .
ITB 21.1	Bid shall include Bid Securing Declaration using the form included in Section IV Bidding Forms
ITB 21.2	The amount of the Bid Security shall be: Not Applicable
ITB 21.7	If the Bidder incurs any of the actions prescribed in subparagraphs (a) or (b) of this provision, the Borrower will declare the Bidder ineligible to be awarded contracts by the Purchaser for a period of 2 years .
ITB 22.1	In addition to the original of the bid, the number of copies is: Not Applicable
D. Submission and Opening of Bids	
ITB 23.1	Bids must be submitted electronically via the GOJ's e-GP system at https://www.gojep.gov.jm . BIDDERS ARE URGED TO COMMENCE BID UPLOAD AT LEAST FOUR (4) HOURS PRIOR TO THE SUBMISSION TIME. THE PROCURING ENTITY WILL NOT BE HELD LIABLE FOR BIDS NOT SUBMITTED ON TIME DUE TO LATE COMMENCEMENT OF BID UPLOAD. AT THE FIRST SIGN OF ANY TECHNICAL DIFFICULTIES, BIDDERS MUST MAKE CONTACT WITH THE MINISTRY OF FINANCE VIA THE CONTACT NUMBERS LISTED ABOVE
ITB 23.1 (b)	Bidders must register and submit their Bids electronically via the GoJ's e-GP Procurement system at https://www.gojep.gov.jm . Follow instructions detailed on the website. The terms and conditions of use and an operating manual of the website are provided on the web portal provided above. Instructions for bid submission are detailed in the "Instruction for Bid Preparation and

	<p>Submission” document found in the contract documents section of this procurement on the said web portal.</p> <p><u>The system has a total file size limit of 99MB for Bid submissions.</u></p> <p><u>The system allows one file to be uploaded. Therefore, kindly be reminded to zip or merge all relevant documents into one file, which will be uploaded to the system.</u></p> <p>It is recommended that bidders submit their bids well in advance of the deadline. This will give sufficient time to resolve technical or network issues which may prevent their bid being transmitted.</p>
ITB 23.2 (c)	The inner and outer envelopes shall bear the following additional identification marks: <i>Not Applicable</i>
ITB 24.1	<p>Your proposal should be done in PDF format and submitted electronically via the GoJ’s e-GP Procurement system at https://www.gojep.gov.jm.</p> <p>No hardcopy document should be submitted.</p> <p>The deadline for the submission of bids is: Date: Monday, September 25, 2023 Time: 4:00 pm</p> <p>All Bids MUST have the required signatures and supporting documentation.</p>
ITB 27.1	<p>Tender opening will be done electronically. An online bid opening report will be sent to all Bidders that submitted a proposal.</p> <p>The bid opening shall take place on: Date: Monday, September 25, 2023 Time: 4:15 pm</p>
E. Evaluation and Comparison of Bids	
ITB 34.1	<p>Bid prices expressed in different currencies shall be converted to: <i>United States Dollars.</i></p> <p>The source of exchange rate shall be: <i>Bank of Jamaica Average Selling Exchange Rate.</i></p> <p>For Evaluation – <i>Date of Bid Opening</i> For Payment – <i>Date of Payment</i></p>
ITB 35.1	Domestic preference shall not be a bid evaluation factor.
ITB 36.3(a)	<p><i>Bids will be evaluated in accordance with the Specification and Requirements set out in the Evaluation and Qualification Criteria to determine the most substantially responsive bid.</i></p> <p><i>If a Price Schedule shows items listed but not priced, their prices shall be assumed to be included in the prices of other items. An item not listed in the Price Schedule shall be assumed to be not included in the bid, and</i></p>

	<i>provided that the bid is substantially responsive, the average price of the item quoted by substantially responsive bidders will be added to the bid price and the equivalent total cost of the bid so determined will be used for price comparison.</i>
ITB 36.3(d)	<i>Not Applicable</i>
ITB 36.6	Bidders <i>shall not</i> be allowed to quote separate prices for the items. The Purchaser reserves the right not to accept the lowest, or any other tender or to abort the tender process and reject all bids at any time prior to award of contract without incurring any liability.
	F. Award of Contract
ITB 40.1	A substantially responsive Bid is one that conforms to all the terms, conditions, and specifications of the Bidding Documents without material deviation, reservation, or omission and has the lowest cost.
ITB 41.1	The maximum percentage by which quantities may be increased is: 20% The maximum percentage by which quantities may be decreased is: 20%

SECTION III. EVALUATION AND QUALIFICATION CRITERIA

1. Evaluation Criteria (ITB 36.3)

This section describes the approach that the Purchaser will adopt during the evaluation of proposals and the level of input that Bidders will be expected to provide during this period. This section also identifies the evaluation timetable and describes the process for awarding a contract.

1.1. Overall Evaluation Process

1. The Bidders' proposals shall be evaluated in keeping with the phases indicated below:
 - i. A preliminary evaluation which entails an examination of the bid document to determine adherence to the eligibility requirements outlined in the BDS pursuant to ITB 4.
 - ii. A detailed evaluation to determine the degree to which the proposals satisfy the technical requirements and specifications.
 - iii. A demonstration by the bidder of the proposed solution and products in accordance with the technical requirements.
 - iv. An evaluation of the quality of the bidder's relevant experience and track record, preliminary implementation plan, warranty and support and training.

1.1.1. Eligibility Requirements

2. To establish eligibility, all Bidders invited to bid shall comply with the following criteria at the time of bid submission:
 - a) Bidders are required to submit a valid Tax Compliance Letter (TCL).
 - b) Bidders are required to submit valid proof of registration with the Public Procurement Commission (PPC).
 - c) A Bidder, and all parties constituting the Bidder, shall be nationals of member countries of the IDB.
 - d) Bidder Information Form
 - e) Bid Submission Form (signed)
 - f) Bid Securing Declaration (signed)
 - g) Price Schedule Form (signed)
 - h) The bidder shall submit all other relevant additional documents outlined in ITB 11.1 (h) above
3. Only the bids, which satisfy the eligibility requirements, will be short-listed for detailed evaluation in subsequent phases. The bids that do not satisfy the eligibility requirements will be deemed as ineligible and will therefore be disqualified.

1.1.2. Detailed Evaluation

4. In this phase of the selection process, the Purchaser shall compare and evaluate all substantially responsive short-listed bids on the following basis:

The determination shall be based on the Bidder's fulfillment of the following:

5. **TECHNICAL QUALITY ASSESSMENT** – The Purchaser shall evaluate all eligible, short-listed bids on the basis of their compliance to all technical requirements stated in Section VII, Requirements and Specifications. Technical quality assessment will be done on each proposal and the scope of work of reference as detailed below:
- a. Compliance with goods and services required – Requirements and Specifications
 - b. Demonstration
 - c. Relevant experience and client references:
 - i. Evidence of past similar projects;
 - ii. Client References
 - d. Preliminary Implementation Plan
 - e. Warranty and Support/After Sales Service
 - f. Training
6. All offers that comply with all instructions given in this document will be ranked according to the following weightings totaling 100%, with a minimum pass mark of 70%:
- Technical Specification – Pass/Fail
 - Critical Requirements – Mandatory
 - Required Requirments – 40%
 - Desired Requirements - 10%
 - Demonstration – 20%
 - Relevant Experience and client references – 20%
 - Preliminary Implementation Plan – 10%

A bid score (S) is calculated using the formula below:

$$S = R + D + R + P$$

Where:

- S = Total Score
- R = Required Requirements Score
- D = Desired Requirements Score
- E = Relevan Experience and Client References Score
- P = Preliminary Implementation Plan

7. **TECHNICAL SPECIFICATIONS** – Each criterion for Requirements and Specifications is given a ‘Pass’ or ‘Fail’ mark as indicated below:
- A ‘Pass’ will be given in cases where the requirements are fully met or exceeded as written
 - A ‘Pass’ will also be given in cases where the requirements are not fully met but is still considered to be substantially acceptable and the deviations are considered minor.
 - A ‘Fail’ will be given in cases where the requirements are not met and deviations are considered major. those requirements will be deemed unacceptable and will therefore be rejected.
8. Only bids which comply to all mandatory requirements will be short-listed for further evaluation. The purchaser reserves the right to deem as non-responsive and reject any short-listed bid that does not match any/all mandatory requirements and technical specifications of the RFP.

9. REQUIREMENTS

A detailed description of the essential technical and performance characteristics of each component making up the surveillance system and other requirements must be done in the table below in the Requirements section in the Scope of Work.

The requirements are categorized and defined as follows:-

- C – critical:** This feature is a critical and mandatory requirement and bids not offering this feature or its equivalent will be rejected
- R – required:** This feature is required to support DCS operations but bids will not necessarily be rejected if the feature is not available
- D – desired:** This feature is not necessarily required to the support DCS operations, but would be a nice feature to have.

The degree of responsiveness as outlined in the table below will be used to determine what percentage of the maximum score (50%) allocated for **Required** and **Desired** Requirements is attained by each bidder.

Degree of Responsiveness	%Score
Excellent	100%
Good	90%
Satisfactory	70%
Poor	40%
Unsatisfactory	0%

10. DEMONSTRATION

1. As a part of technical evaluation, short listed bidders will be invited to conduct a demonstration the proposed solution to the Purchaser. The demonstration must include:
 - i. live viewing of the cameras being proposed;
 - ii. recorded footage of night time capture;
 - iii. interaction of the NVR's interface and
 - iv. demonstration of alert/security features.
2. The solution will be evaluated vis-à-vis the technical specifications mentioned in the RFP document and the software / hardware integration, as applicable.
3. The degree of responsiveness as outlined in the table above will be used to determine what percentage of the maximum score (20%) allocated for **Demonstration** is attained by each bidder.
4. The bidder whose proposed products fail to match the minimum technical specifications mentioned in the RFP are liable for disqualifications. Demonstrations will be conducted at the bidder's expense and can be conducted remotely or on premises. The date and time for the demonstration of the proposed product will be communicated to the bidder. Bidders will be given approximately two (2) weeks to prepare their demonstration.
5. Validation –During the presentation, each bidder is also requested to provide a brief overview of their company, upcoming product roadmap as well as solutions, options, operations support, support services, reporting implementation approach and commercial considerations. The presentation is also meant to reinforce key responses as outlined in the bidder's written submissions.

11. RELEVANT EXPERIENCE AND CLIENT REFERENCES

Objective: To establish the general capability of the bidders and their staff to perform the requirements specified in the scope of work of the project.

12. Evidence of past experience in implementing projects of a similar size and nature:

Eight (8) years' experience in surveillance connectivity design and implementation:

- | | |
|--------------------------------|----|
| ▪ 8 or more years' experience: | 10 |
| ▪ 4 – 7 years' experience: | 8 |
| ▪ 1 – 3 years' experience: | 5 |
| ▪ No experience: | 0 |

13. Client Reference Score:

Participating bidders shall submit with their bid, at least three (3) Client References for whom projects of a similar size and nature have been successfully implemented, as points will be awarded as follows. The Purchaser reserves the right to contact references for verification of work done and past performance. Please see *Section V* for *Client Reference Form*.

- | | |
|--------------------------------|----|
| ▪ Three or more (3) References | 10 |
| ▪ Two (2) References | 8 |
| ▪ One (1) Reference | 5 |
| ▪ No Reference | 0 |

14. PRELIMINARY IMPLEMENTATION PLAN – The vendor is required to implement, commission and test the systems as specified. A preliminary implementation plan is required upon bid submission. A full implementation plan will be required subsequent to the award of contract. The evaluation of bids shall take into account the bidders' plan for implementation to the target site(s).

15. Implementation Objective:

The objective of the Supplier is to supply, install and configure all the equipment specified in the requirements and specifications in the table below to the extent that it provides the necessary logical connectivity between the intended sites.

16. The Supplier will:

- Supply and deliver all the equipment specified in the requirements and specification.
- Install all the equipment specified in the requirements and specification as per manufacturer's instructions. All installations must be certified.
- Develop and execute the quality plan for Installation, testing the deployed network components

17. The Degree of Responsiveness of the Requirements

The Purchaser will assess the Supplier's response as indicated in the matrix below. The degree of responsiveness will be used to determine what percentage of the maximum score of 20 allocated for the Implementation Plan is attained by each bidder.

Degree of Responsiveness	%Score	Actual Score
Excellent	100%	10
Good	90%	9
Satisfactory	70%	7
Poor	40%	4
Unsatisfactory	0%	0

18. Delivery

Vendors are responsible to deliver, install and commission the items in the Schedule of Requirements for the listed sites(s) on or before the timeline given in their proposal. Failure to deliver on time will result in delivery penalties. Refer to Policies for the Procurement of Goods and Work Financed by the Inter-America Development Bank (GN-2349-9) paragraph 2.41. Liquidated Damages and Bonus Clauses. The penalty for late delivery shall be 0.5% of contract price per day up a maximum of 10%.

Vendors must specify the exact time of delivery in days (e.g. 21 days) and not in a range (e.g. 14-21). For vendor whose delivery proposals are submitted in a range, the latest time will be used to determine the period of delivery. Beginning at the date issue of Purchase Order (Contract) to the preferred vendor, the goods must land at the Wharf in Jamaica W.I. on or before the delivery date listed in Vendor's proposal. Failure to comply will result in delivery penalties as stated above.

19. WARRANTY AND SUPPORT/MAINTENANCE, TRAINING AND AFTER SALE SERVICE

The bidder shall include in its bid where applicable, details of warranty and support/maintenance, training and after sale service for the goods and services being offered.

20. The Degree of Responsiveness of the Requirements

The Purchaser will assess the Supplier's response as indicated in the requirements matrix . The degree of responsiveness as outlined above will also be used to determine what percentage of the maximum score is allocated for *warranty and support/maintenance, training and after sale service* is attained by each bidder.

21. COST ASSESSMENT – Short-listed bids will be examined to determine whether they are complete, free from any computational errors and whether the quotations are generally in order. Arithmetical errors will be rectified on the following basis:

- a. If there exists a discrepancy between the product of the unit price and the quantity on one hand and the corresponding price entered in the schedule on the other, the unit price will prevail and the corresponding total price (extended price) will be corrected;
- b. If there exists a discrepancy between the sum of individual prices and the corresponding total price entered in the proposal, the individual prices will prevail and the total price will be corrected;
- c. If there exists a discrepancy between words and figures, the amount in words will prevail, unless the amount expressed in words is related to an arithmetic error in which case the amount will prevail subject to (a) and (b) above.

22. The Purchaser shall consider the price adjustment due to discounts offered in accordance with ITB Sub-Clause 14.8.

23. If the successful Bidder with the lowest evaluated bid (that is the bid that is substantially responsive and has the highest bid score) refuses to accept the correction of errors, its bid shall be disqualified. In the event of disqualification of the bid, the Purchaser shall proceed to the next lowest evaluated bid and follow the same procedure as above.
24. The Bidder should make preparatory arrangements to ensure that Bidder's staff is available to assist the Purchaser during the evaluation process.
25. All contact between the Bidder and the Purchaser during the evaluation period should be initiated by the Purchaser. Any unsolicited contact initiated by the Bidder during this period may be construed as an attempt to influence the Purchaser's evaluation and may result in the Bidder's proposal being rejected.
26. Subject to the assessment of the proposals, the purchaser will award the contract to the vendor whose proposal has been determined to be substantially responsive and has lowest evaluated bid price. The financial capacity of the bidder to supply the goods proposed may also be assessed to determine if the bidder is qualified to perform the contract satisfactorily.

RE TENDERED

SECTION IV. BIDDING FORMS

Bidder Information Form	38
Joint Venture Partner Information Form	39
Bid Submission Form	40
Price Schedule Forms	42
Bid Security Form.....	46
Form of Bid Security	48
Bid-Securing Declaration	49
Manufacturer’s Authorization	50

RE TENDERED

Section IV. Bidding Forms

Bidder Information Form

[The Bidder shall fill in this Form in accordance with the instructions indicated below. No alterations to its format shall be permitted and no substitutions shall be accepted.]

Date: *[insert date (as day, month and year) of Bid Submission]*

ICB No.: *[insert number of bidding process]*

Page _____ of _____ pages

1. Bidder's Legal Name <i>[insert Bidder's legal name]</i>
2. In case of JV, legal name of each party: <i>[insert legal name of each party in JV]</i>
3. Bidder's actual or intended Country of Registration: <i>[insert actual or intended Country of Registration]</i>
4. Bidder's Year of Registration: <i>[insert Bidder's year of registration]</i>
5. Bidder's Legal Address in Country of Registration: <i>[insert Bidder's legal address in country of registration]</i>
6. Bidder's Authorized Representative Information Name: <i>[insert Authorized Representative's name]</i> Address: <i>[insert Authorized Representative's Address]</i> Telephone/Fax numbers: <i>[insert Authorized Representative's telephone/fax numbers]</i> Email Address: <i>[insert Authorized Representative's email address]</i>
7. Attached are copies of original documents of: <i>[check the box(es) of the attached original documents]</i> <input type="checkbox"/> Articles of Incorporation or Registration of firm named in 1, above, in accordance with ITB Sub-Clauses 4.1 and 4.2. <input type="checkbox"/> In case of JV, letter of intent to form JV or JV agreement, in accordance with ITB Sub-Clause 4.1. <input type="checkbox"/> In case of government owned entity from the Purchaser's country, documents establishing legal and financial autonomy and compliance with commercial law, in accordance with ITB Sub-Clause 4.5.

Joint Venture Partner Information Form

[The Bidder shall fill in this Form in accordance with the instructions indicated below]

Date: *[insert date (as day, month and year) of Bid Submission]*

ICB No.: *[insert number of bidding process]*

Page _____ of _____ pages

1. Bidder's Legal Name: <i>[insert Bidder's legal name]</i>
2. JV's Party legal name: <i>[insert JV's Party legal name]</i>
3. JV's Party Country of Registration: <i>[insert JV's Party country of registration]</i>
4. JV's Party Year of Registration: <i>[insert JV's Party year of registration]</i>
5. JV's Party Legal Address in Country of Registration: <i>[insert JV's Party legal address in country of registration]</i>
6. JV's Party Authorized Representative Information Name: <i>[insert name of JV's Party authorized representative]</i> Address: <i>[insert address of JV's Party authorized representative]</i> Telephone/Fax numbers: <i>[insert telephone/fax numbers of JV's Party authorized representative]</i> Email Address: <i>[insert email address of JV's Party authorized representative]</i>
7. Attached are copies of original documents of: <i>[check the box(es) of the attached original documents]</i> <input type="checkbox"/> Articles of Incorporation or Registration of firm named in 2, above, in accordance with ITB Sub-Clauses 4.1 and 4.2. <input type="checkbox"/> In case of government owned entity from the Purchaser's country, documents establishing legal and financial autonomy and compliance with commercial law, in accordance with ITB Sub-Clause 4.5.

Bid Submission Form

[The Bidder shall fill in this Form in accordance with the instructions indicated No alterations to its format shall be permitted and no substitutions shall be accepted.]

Date: *[insert date (as day, month and year) of Bid Submission]*

ICB No.: *[insert number of bidding process]*

Invitation for Bid No.: *[insert No of IFB]*

Alternative No.: *[insert identification No if this is a Bid for an alternative]*

To: *[insert complete name of Purchaser]*

We, the undersigned, declare that:

- (a) We have examined and have no reservations to the Bidding Documents, including Addenda No.: *[insert the number and issuing date of each Addenda]*;
- (b) We offer to supply in conformity with the Bidding Documents and in accordance with the Delivery Schedules specified in the Schedule of Requirements the following Goods and Related Services *[insert a brief description of the Goods and Related Services]*;
- (c) The total price of our Bid, excluding any discounts offered in item (d) below, is: *[insert the total bid price in words and figures, indicating the various amounts and the respective currencies]*;
- (d) The discounts offered and the methodology for their application are:
 - Discounts.** If our bid is accepted, the following discounts shall apply: *[Specify in detail each discount offered and the specific item of the Schedule of Requirements to which it applies.]*
 - Methodology of Application of the Discounts.** The discounts shall be applied using the following method: *[Specify in detail the method that shall be used to apply the discounts]*;
- (e) Our bid shall be valid for the period of time specified in ITB Sub-Clause 20.1, from the date fixed for the bid submission deadline in accordance with ITB Sub-Clause 24.1, and it shall remain binding upon us and may be accepted at any time before the expiration of that period;
- (f) If our bid is accepted, we commit to obtain a performance security in accordance with ITB Clause 44 and GCC Clause 18 for the due performance of the Contract;
- (g) We, including any subcontractors or suppliers for any part of the contract, have nationality from eligible countries *[insert the nationality of the Bidder, including that of all parties that comprise the Bidder, if the Bidder is a JV, and the nationality each subcontractor and supplier]*
- (h) We have no conflict of interest in accordance with ITB Sub-Clause 4.2;
- (i) Our firm, its affiliates or subsidiaries—including any subcontractors or suppliers for any part of the contract—has not been declared ineligible by the Bank, under the Purchaser's country laws or official regulations, in accordance with ITB Sub-Clause 4.3;
- (j) We have do not have any outstanding sanctions from the Bank or any other International Financial Institution.
- (k) We will use our best efforts to assist the Bank in any investigation.

- (l) We hereby agree that in competing for (and, if the award is made to us, in executing) the Contract, we undertake to observe the laws against fraud and corruption, including bribery, in force in the country of the Client.
- (m) The following commissions, gratuities, or fees have been paid or are to be paid with respect to the bidding process or execution of the Contract: *[insert complete name of each Recipient, its full address, the reason for which each commission or gratuity was paid and the amount and currency of each such commission or gratuity]*

Name of Recipient	Address	Reason	Amount
_____	_____	_____	_____
_____	_____	_____	_____
_____	_____	_____	_____
_____	_____	_____	_____

(If none has been paid or is to be paid, indicate “none.”)

- (k) We understand that this bid, together with your written acceptance thereof included in your notification of award, shall constitute a binding contract between us, until a formal contract is prepared and executed.
- (l) We understand that you are not bound to accept the lowest evaluated bid or any other bid that you may receive.

Signed: *[insert signature of person whose name and capacity are shown]*

In the capacity of *[insert legal capacity of person signing the Bid Submission Form]*

Name: *[insert complete name of person signing the Bid Submission Form]*

Duly authorized to sign the bid for and on behalf of: *[insert complete name of Bidder]*

Dated on *[insert date of signing]*

PRICE SCHEDULE FORMS

*[The Bidder shall fill in these Price Schedule Forms in accordance with the instructions indicated. The list of line items in column 1 of the **Price Schedules** shall coincide with the List of Goods and Related Services specified by the Purchaser in the Schedule of Requirements.]*

Price Schedule: Goods Manufactured Outside the Purchaser's Country, to be Imported

(Group C bids, goods to be imported)						Date: _____
Currencies in accordance with ITB Sub-Clause 15						ICB No: _____
						Alternative No: _____
						Page N° _____ of _____
1	2	3	4	5	6	7
Line Item N°	Description of Goods	Country of Origin	Delivery Date as defined by Incoterms	Quantity and physical unit	Unit price CIP <i>[insert place of destination]</i> in accordance with ITB 14.6(b)(i)	CIP Total Price per line item (Col. 5x6)
<i>[insert # of item]</i>	<i>[insert name of good]</i>	<i>[insert country of origin of the Good]</i>	<i>[insert quoted Delivery Date]</i>	<i>[insert # of units to be supplied and name of the physical unit]</i>	<i>[insert unit price CIP per unit]</i>	<i>[insert total CIP price per line item]</i>
Total Price						

Name of Bidder *[insert complete name of Bidder]* Signature of Bidder *[signature of person signing the Bid]* Date *[Insert Date]*

Price Schedule: Goods Manufactured Outside the Purchaser's Country, already imported

(Group C bids, Goods already imported)

Currencies in accordance with ITB Sub-Clause 15

Date: _____

ICB No: _____

Alternative No: _____

Page N° ____ of ____

1	2	3	4	5	6	7	8	9	10
Line Item N°	Description of Goods	Country of Origin	Delivery Date as defined by Incoterms	Quantity and physical unit	Unit price CIP including Custom Duties and Import Taxes paid, in accordance with ITB 14.6(c)(i)	Custom Duties and Import Taxes paid per unit in accordance with ITB 14.6(c)(ii), <i>[to be supported by documents]</i>	Unit Price CIP net of custom duties and import taxes, in accordance with ITB 14.6 (c) (iii) (Col. 6 minus Col.7)	Price CIP per line item net of Custom Duties and Import Taxes paid, in accordance with ITB 14.6(c)(i) (Col. 5×8)	Sales and other taxes paid or payable per item if Contract is awarded (in accordance with ITB 14.6(c)(iv))
<i>[insert number of the item]</i>	<i>[insert name of Goods]</i>	<i>[insert country of origin of the Good]</i>	<i>[insert quoted Delivery Date]</i>	<i>[insert number of units to be supplied and name of the physical unit]</i>	<i>[insert unit CIP price per unit]</i>	<i>[insert custom duties and taxes paid per unit]</i>	<i>[insert unit CIP price net of custom duties and import taxes]</i>	<i>[insert CIP price per line item net of custom duties and import taxes]</i>	<i>[insert sales and other taxes payable per item if Contract is awarded]</i>
								Total Bid Price	

Name of Bidder *[insert complete name of Bidder]* Signature of Bidder *[signature of person signing the Bid]* Date *[insert date]*

Price Schedule: Goods Manufactured in the Purchaser's Country

Purchaser's Country _____		(Group A and B bids) Currencies in accordance with ITB Sub-Clause 15				Date: _____ ICB No: _____ Alternative No: _____ Page N° ____ of ____	
1	2	3	4	5	6	7	8
Line Item N°	Description of Goods	Delivery Date as defined by Incoterms	Quantity and physical unit	Unit price CIP (named place of destination)	Total CIP price per line item (Col. 4x5)	Cost of local labor, raw materials and components from of origin in the Purchaser's Country % of Col. 5	Sales and other taxes payable per item if Contract is awarded (in accordance with ITB 14.6(a)(ii))
<i>[insert number of the item]</i>	<i>[insert name of Good]</i>	<i>[insert quoted Delivery Date]</i>	<i>[insert number of units to be supplied and name of the physical unit]</i>	<i>[insert CIP unit price]</i>	<i>[insert total CIP price per line item]</i>	<i>[Insert cost of local labor, raw material and components from within the Purchase's country as a % of the CIP price per line item]</i>	<i>[insert sales and other taxes payable per line item if Contract is awarded]</i>
Total Price							

Name of Bidder *[insert complete name of Bidder]* Signature of Bidder *[signature of person signing the Bid]* Date *[insert date]*

Price and Completion Schedule - Related Services

Currencies in accordance with ITB Sub-Clause 15						Date: _____
						ICB No: _____
						Alternative No: _____
						Page N° <u> </u> of <u> </u>
1	2	3	4	5	6	7
Service N°	Description of Services (excludes inland transportation and other services required in the Purchaser's country to convey the goods to their final destination)	Country of Origin	Delivery Date at place of Final destination	Quantity and physical unit	Unit price	Total Price per Service (Col. 5*6 or estimate)
<i>[insert number of the Service]</i>	<i>[insert name of Services]</i>	<i>[insert country of origin of the Services]</i>	<i>[insert delivery date at place of final destination per Service]</i>	<i>[insert number of units to be supplied and name of the physical unit]</i>	<i>[insert unit price per item]</i>	<i>[insert total price per item]</i>
					Total Bid Price	

Name of Bidder *[insert complete name of Bidder]* Signature of Bidder *[signature of person signing the Bid]* Date *[insert date]*

Bid Security Form
(Bank Guarantee)

[The Bank shall fill in this Bank Guarantee Form in accordance with the instructions indicated.]
[Guarantor letterhead or SWIFT identifier code]

Beneficiary: *[Purchaser to insert its name and address]*

IFB No.: *[Purchaser to insert reference number for the Invitation for Bids]*

Alternative No.: *[Insert identification No if this is a Bid for an alternative]*

Date: *[Insert date of issue]*

BID GUARANTEE No.: *[Insert guarantee reference number]*

GUARANTOR: *[Insert name and address of place of issue, unless indicated in the letterhead]*

We have been informed that *[insert name of the Bidder, which in the case of a joint venture shall be the name of the joint venture (whether legally constituted or prospective) or the names of all members thereof]* (hereinafter called "the Applicant") has submitted or will submit to the Beneficiary its bid (hereinafter called "the Bid") for the execution of *[insert description of goods]* under Invitation for Bids No. *[insert number]* ("the IFB").

Furthermore, we understand that, according to the Beneficiary's conditions, bids must be supported by a bid guarantee.

At the request of the Applicant, we, as Guarantor, hereby irrevocably undertake to pay the Beneficiary any sum or sums not exceeding in total an amount of *[insert amount]* (*[insert amount in numbers]*) upon receipt by us of the Beneficiary's complying demand, supported by the Beneficiary's statement, whether in the demand itself or a separate signed document accompanying or identifying the demand, stating that either the Applicant:

- (a) has withdrawn its Bid during the period of bid validity set forth in the Applicant's Letter of Bid ("the Bid Validity Period"), or any extension thereto provided by the Applicant; or
- (b) having been notified of the acceptance of its Bid by the Beneficiary during the Bid Validity Period or any extension thereto provided by the Applicant, (i) has failed to execute the contract agreement, or (ii) has failed to furnish the performance security, accordance with the Instructions to Bidders ("ITB") of the Beneficiary's bidding document.

This guarantee will expire: (a) if the Applicant is the successful bidder, upon our receipt of copies of the contract agreement signed by the Applicant and the performance security issued to the Beneficiary in relation to such contract agreement; or (b) if the Applicant is not the successful bidder, upon the earlier of (i) our receipt of a copy of the Beneficiary's notification to the Applicant of the results of the bidding process; or (ii) twenty-eight days after the end of the Bid Validity Period.

Consequently, any demand for payment under this guarantee must be received by us at the office indicated above on or before that date.

This guarantee is subject to the Uniform Rules for Demand Guarantees (URDG) 2010 Revision, ICC Publication No. 758, except that the supporting statement under Article 15(a) is hereby excluded*.

[signature(s)]

*Note: *Information for the Executing Agency: Article 15 (a) states: "Requirements for Demand: (a) A demand under the guarantee shall be supported by such other documents as the guarantee specifies, and in any event by a statement, by the beneficiary, indicating in what respect the applicant is in breach of its obligations under the underlying relationship. This statement may be in the demand or in a separate document accompanying or identifying the demand."*

[Signature(s)]

[Note: All italicized text is for use in preparing this form and shall be deleted from the final product.]

RE TENDERED

Form of Bid Security
(Bid Bond)

[The Surety shall fill in this Bid Bond Form in accordance with the instructions indicated.]

BOND NO. _____

BY THIS BOND *[name of Bidder]* as Principal (hereinafter called “the Principal”), and *[name, legal title, and address of surety]*, **authorized to transact business in** *[name of country of Purchaser]*, as Surety (hereinafter called “the Surety”), are held and firmly bound unto *[name of Purchaser]* as Obligee (hereinafter called “the Purchaser”) in the sum of *[amount of Bond]*¹ *[amount in words]*, for the payment of which sum, well and truly to be made, we, the said Principal and Surety, bind ourselves, our successors and assigns, jointly and severally, firmly by these presents.

WHEREAS the Principal has submitted or will submit a written Bid to the Purchaser dated the ___ day of _____, 20___, for the supply of *[name of Contract]* (hereinafter called the “Bid”).

NOW, THEREFORE, THE CONDITION OF THIS OBLIGATION is such that if the Principal:

- (a) has withdrawn its Bid during the period of bid validity set forth in the Principal’s Letter of Bid (“the Bid Validity Period”), or any extension thereto provided by the Principal; or
- (b) having been notified of the acceptance of its Bid by the Purchaser during the Bid Validity Period or any extension thereto provided by the Principal; (i) failed to execute the contract agreement; or (ii) has failed to furnish the Performance Security, in accordance with the Instructions to Bidders (“ITB”) of the Purchaser’s bidding document.

then the Surety undertakes to immediately pay to the Purchaser up to the above amount upon receipt of the Purchaser’s first written demand, without the Purchaser having to substantiate its demand, provided that in its demand the Purchaser shall state that the demand arises from the occurrence of any of the above events, specifying which event(s) has occurred.

The Surety hereby agrees that its obligation will remain in full force and effect up to and including the date 28 days after the date of expiration of the Bid Validity Period set forth in the Principal’s Letter of Bid or any extension thereto provided by the Principal.

IN TESTIMONY WHEREOF, the Principal and the Surety have caused these presents to be executed in their respective names this ___ day of _____ 20___.

Principal:

Corporate Seal (where appropriate)

Surety:

(Signature)
(Printed name and title)

(Signature)
(Printed name and title)

[The Bidder shall fill in this Form in accordance with the instructions indicated.]

¹ The amount of the Bond shall be denominated in the currency of the Purchaser’s country or the equivalent amount in a freely convertible currency.

Bid-Securing Declaration

Date: *[date (as day, month and year)]*

Bid No.: *[number of bidding process]*

Alternative No.: *[identification No if this is a Bid for an alternative]*

To: *Ministry of National Security*

We, the undersigned, declare that:

We understand that, according to your conditions, bids must be supported by a Bid-Securing Declaration.

We accept that we will automatically be suspended from being eligible for bidding in any contract with the Purchaser for the period of time of *two (2) years* starting on *date of withdrawal in the case of clause (a) below OR date of contract award in the case of clause (b) below*, if we are in breach of our obligation(s) under the bid conditions, because we:

- (a) have withdrawn our Bid during the period of bid validity specified in the Form of Bid; or
- (b) having been notified of the acceptance of our Bid by the Purchaser during the period of bid validity, fail or refuse to execute the Contract; or (ii) fail or refuse to furnish the Performance Security, if required, in accordance with the ITB.

We understand this Bid Securing Declaration shall expire if we are not the successful Bidder, upon the earlier of (i) our receipt of your notification to us of the name of the successful Bidder; or (ii) twenty-eight days after the expiration of our Bid.

Signed: *[signature of person whose name and capacity are shown]* In the capacity of *[legal capacity of person signing the Bid Securing Declaration]*

Name: *[complete name of person signing the Bid Securing Declaration]*

Duly authorized to sign the bid for and on behalf of: *[complete name of Bidder]*

Dated *[date of signing]*

Corporate Seal (where appropriate)

[Note: In case of a Joint Venture, the Bid Securing Declaration must be in the name of all partners to the Joint Venture that submits the bid.]

Manufacturer's Authorization

*[The Bidder shall require the Manufacturer to fill in this Form in accordance with the instructions indicated. This letter of authorization should be on the letterhead of the Manufacturer and should be signed by a person with the proper authority to sign documents that are binding on the Manufacturer. The Bidder shall include it in its bid, if so indicated in the **BDS**.]*

Date: *[insert date (as day, month and year) of Bid Submission]*

ICB No.: *[insert number of bidding process]*

Alternative No.: *[insert identification No if this is a Bid for an alternative]*

To: *[insert complete name of Purchaser]*

WHEREAS

We *[insert complete name of Manufacturer]*, who are official manufacturers of *[insert type of goods manufactured]*, having factories at *[insert full address of Manufacturer's factories]*, do hereby authorize *[insert complete name of Bidder]* to submit a bid the purpose of which is to provide the following Goods, manufactured by us *[insert name and or brief description of the Goods]*, and to subsequently negotiate and sign the Contract.

We hereby extend our full guarantee and warranty in accordance with Clause 28 of the General Conditions of Contract, with respect to the Goods offered by the above firm.

Signed: *[insert signature(s) of authorized representative(s) of the Manufacturer]*

Name: *[insert complete name(s) of authorized representative(s) of the Manufacturer]*

Title: *[insert title]*

Dated on *[insert date of signing]*

Client Referenc Form

Contracts of Similar Size and Nature

No	Description of Work/Service Provided	Period of Time		Contract Value	Name of Client	Client Contact Info (Tel, Email)
		From	To			
1						
2						
3						
4						
5						

SECTION V. ELIGIBLE COUNTRIES

Eligibility for the Provision of Goods, Works and Services in Bank-Financed Procurement

List of Member Countries and Territories when the Inter-American Development Bank is financing:

Argentina, Austria, Bahamas, Barbados, Belgium, Belize, Bolivia, Brazil, Canada, Colombia, Costa Rica, Chile, Croatia, Denmark, Dominican Republic, Ecuador, El Salvador, Finland, France, Germany, Guatemala, Guyana, Haiti, Honduras, Israel, Italy, Jamaica, Japan, Mexico, Netherlands, Nicaragua, Norway, Panama, Paraguay, People's Republic of China, Peru, Portugal, Republic of Korea, Slovenia, Spain, Suriname, Sweden, Switzerland, Trinidad & Tobago, United Kingdom, United States, Uruguay and Venezuela.

Eligible Territories

- a) Guadeloupe, French Guiana, Martinique, Reunion – as Departments of France
- b) U.S. Virgin Islands, Puerto Rico, Guam – as Territories of the USA
- c) Aruba – as a constituent country of the Kingdom of the Netherlands; and Bonaire, Curacao, Saint Marten, Saba, St Eustatius – as Departments of the Kingdom of the Netherlands
- d) Hong Kong – as a Special Administrative Region of the People's Republic of China

Nationality and origin of Goods and Services Criteria

These policy provisions make it necessary to establish criteria to determine: a) the nationality of the firms and individuals eligible to bid or participate in a bank-financed contract and b) the country of origin of goods, and services. For these determinations, the following criteria shall be used:

A. Nationality.

- (a) An individual is considered to be a national of a member country of the Bank if he or she meets either of the following requirements:
 - is a citizen of a member country; or
 - has established his/her domicile in a member country as a “bona fide” resident and is legally entitled to work in the country of domicile.
- (b) A firm is considered to have the nationality of a member country if it meets the two following requirements:
 - is legally constituted or incorporated under the laws of a member country of the Bank; and
 - more than fifty percent (50%) of the firm's capital is owned by individuals or firms from member countries of the Bank.

All members of a JVCA and all subcontractors must meet the nationality criteria set forth above.

B. Origin of Goods.

Goods have their origin in a member country of the Bank if they have been mined, grown, harvested, or produced in a member country of the Bank. A good has been produced when through manufacture, processing or assembly another commercially recognized article results that differs substantially in its basic characteristics, function or purpose of utility from its parts or components.

For a good consisting of several individual components that need to be interconnected (either by the supplier, the purchaser or by a third party) to make the good operative and regardless of the complexity of the interconnection, the Bank considers that such good is eligible for financing if the assembly of the components took place in a member country, regardless of the origin of the components. When the good is a set of several individual goods that are normally packaged and sold commercially as a single unit, the good is considered to originate in the country where the set was packaged and shipped to the purchaser.

For purpose of origin, goods labeled “made in the European Union” shall be eligible without the need to identify the corresponding specific country of the European Union.

The origin of materials, parts or components of the goods or the nationality of the firm that produces, assembles, distributes or sells the goods, does not determine the origin of the goods.

C. Origin of Services.

The country of origin of services is that of the individual or firm providing the services as determined under the nationality criteria set forth above. These criteria apply to services ancillary to the supply of goods (such as transportation, insurance, erection, assembly, etc.), to construction services and to consulting services.

SECTION VI. PROHIBITED PRACTICES

Prohibited Practices

1. The Bank requires that all Borrowers (including grant beneficiaries), Executing Agencies and Contracting Agencies as well as all firms, entities and individuals bidding for or participating in a Bank-financed activity including, inter alia, applicants, bidders, suppliers, contractors, consultants, personnel, sub-contractors, sub-consultants, service providers and concessionaires (including their respective officers, employees and agents irrespective of whether the agency is express or implied), adhere to the highest ethical standards, and report to the Bank² all suspected acts of Prohibited Practices of which they have knowledge or become aware both, during the bidding process and throughout negotiation or execution of a contract. Prohibited Practices include acts of: (i) corrupt practices, (ii) fraudulent practices, (iii) coercive practices, and (iv) collusive practices and (v) obstructive practices. The Bank has established mechanisms to report allegations of Prohibited Practices. Any allegation shall be submitted to the Bank's Office of Institutional Integrity (OII) for the appropriate investigation. The Bank has also adopted sanctions procedures to adjudicate cases. The Bank has also entered into agreements with other International Financial Institutions (IFIs) to mutually recognize sanctions imposed by their respective sanctioning bodies.
 - (a) The Bank defines, for the purposes of this provision, the terms set forth below:
 - (i) A "corrupt practice" which is the offering, giving, receiving, or soliciting, directly or indirectly, anything of value to influence improperly the actions of another party;
 - (ii) A "fraudulent practice" is any act or omission, including a misrepresentation, that knowingly or recklessly misleads, or attempts to mislead, a party to obtain a financial or other benefit or to avoid an obligation;
 - (iii) A "coercive practice" is impairing or harming, or threatening to impair or harm, directly or indirectly, any party or the property of the party to influence improperly the actions of a party;
 - (iv) A "collusive practice" is an arrangement between two or more parties designed to achieve an improper purpose, including influencing improperly the actions of another party; and
 - (v) An "obstructive practice" which is:
 - a. deliberately destroying, falsifying, altering or concealing evidence material to the investigation or making false statements to investigators in order to materially impede a Bank Group investigation into allegations of a corrupt, fraudulent, coercive or collusive practice; and/or threatening, harassing or intimidating any party to prevent it from disclosing its knowledge of matters relevant to the investigation or from pursuing the investigation; or
 - b. acts intended to materially impede the exercise of the Bank's inspection and audit rights provided for under paragraph 1 (f) below.

² Information on how to present allegations of Prohibited Practices, the applicable rules regarding the investigation and sanctions process, and the agreement regulating the mutual recognition of sanctions among the IFIs are available on the Bank's website (www.iadb.org/integrity).

- (b) If, in accordance with the Sanctions Procedures of the Bank, it is determined that at any stage of the procurement or implementation of a contract any firm, entity or individual bidding for or participating in a Bank-financed activity including, inter alia, applicants, bidders, suppliers, contractors, consultants, personnel, sub-contractors, sub-consultants, goods or service providers, concessionaires, Borrowers (including grant Beneficiaries) Executing Agencies or Contracting Agencies (including their respective officers, employees and agents irrespective of whether the agency is express or implied) engaged in a Prohibited Practice the Bank may:
- (i) not finance any proposal to award a contract for works, goods or services, and consulting services;
 - (ii) suspend disbursement of the operation if it is determined at any stage that an employee, agent or representative of the Borrower, Executing Agency or Contracting Agency has engaged in a Prohibited Practice;
 - (iii) declare Misprocurement and cancel, and/or accelerate repayment of the portion of a loan or grant earmarked for a contract, when there is evidence that the representative of the Borrower, or Beneficiary of a grant, has not taken the adequate remedial measures (including, inter alia, providing adequate notice to the Bank upon learning of the Prohibited Practice) within a time period which the Bank considers reasonable;
 - (iv) issue the firm, entity or individual a reprimand in the form of a formal letter of censure for its behavior;
 - (v) declare that a firm, entity, or individual is ineligible, either permanently or for a stated period of time, to (i) be awarded a contract or participate in activities financed by the Bank; and (ii) be nominated³ sub-consultant, sub-contractor, supplier or service provider of an otherwise eligible firm being awarded a Bank-financed contract;
 - (vi) refer the matter to appropriate law enforcement authorities; and/or
 - (vii) impose other sanctions that it deems to be appropriate under the circumstances, including the imposition of fines representing reimbursement of the Bank for costs associated with investigations and proceedings. Such other sanctions may be imposed in addition to or in lieu of the sanctions referred above.
- (c) The provisions of sub-paragraphs 1 (b) (i) and (ii) shall also be applicable when such parties have been temporarily suspended from eligibility to be awarded additional contracts pending a final outcome of a sanction proceeding, or otherwise.
- (d) The imposition of any action to be taken by the Bank pursuant to the provisions referred to above will be public.
- (e) In addition, any firm, entity or individual bidding for or participating in a Bank-financed activity including, inter alia, applicants, bidders, suppliers, contractors, consultants, personnel, sub-contractors, sub-consultants, service providers, concessionaires, Borrowers (including grant Beneficiaries), Executing Agencies or Contracting Agencies (including their respective officers, employees, and agents, irrespective of whether the agency is express or implied) may be subject to sanctions pursuant to agreements that the Bank may

³ A nominated sub-consultant, sub-contractor, supplier, or service provider (different names are used depending on the particular bidding document) is one which has either been: (i) included by the bidder in its pre-qualification application or bid because it brings specific and critical experience and know-how that allow the bidder to meet the qualification requirements for the particular bid; or (ii) appointed by the Borrower.

have with other International Financial Institutions (IFIs) regarding the mutual enforcement of debarment decisions. For purposes of this paragraph the term “sanction” shall mean any debarment, conditions on future contracting or any publicly-disclosed action taken in response to a violation of an IFI’s applicable framework for addressing allegations of Prohibited Practices.

- (f) The Bank requires that all applicants bidders, suppliers, and their agents, contractors, consultants, personnel, sub-contractors, service providers and concessionaires permit the Bank to inspect any and all accounts, records and other documents relating to the submission of bids and contract performance as well as to have them audited by auditors appointed by the Bank. Applicants, bidders, suppliers, and their agents, contractors, consultants, sub-contractors, sub-consultants, service providers and concessionaires shall fully assist the Bank with its investigation. The Bank also requires that all applicants, bidders, suppliers, and their agents, contractors, consultants, personnel, sub-contractors, sub-consultants, service providers and concessionaires: (i) maintain all documents and records related to the Bank-financed activities for seven (7) years after completion of the work contemplated in the relevant contract; and (ii) deliver any document necessary for the investigation of allegations of Prohibited Practices and make available employees or agents of the applicants, bidders, suppliers and their agents, contractors, consultants, personnel, sub-contractors, sub-consultants, service providers or concessionaires with knowledge of the Bank-financed activities to respond to questions from Bank personnel or any properly designated investigator, agent, auditor or consultant relating to the investigation. If the applicant, bidder, supplier and its agent, contractor, consultant, personnel, sub-contractor, sub-consultant, service provider or concessionaire fails to cooperate and/or comply with the Bank’s request, or otherwise obstructs the investigation, the Bank, in its sole discretion, may take appropriate action against the applicant bidder, supplier and its agent, contractor, consultant, personnel, sub-contractor, service provider or concessionaire.
- (g) If the Borrowers procures goods or services, works or consulting services directly from a specialized agency, all provisions under Section VI regarding sanctions and Prohibited Practices shall apply in their entirety to applicants, bidders, suppliers and their agents, contractors, consultants, personnel, sub-contractors, sub-consultants, service providers, and concessionaires, (including their respective officers, employees, and agents, irrespective of whether the agency is express or implied), or to any other entities that signed contracts with such specialized agency to supply such goods, works, or non-consulting services in connection with the Bank-financed activities. The Bank will retain the right to require the Borrower to invoke remedies such as contract suspension or termination. Specialized agencies shall consult the Bank’s list of firms and individuals suspended or debarred. In the event a specialized agency signs a contract or purchase order with a firm or an individual suspended or debarred by the Bank, the Bank will not finance the related expenditures and will apply other remedies as appropriate.
2. By submitting bids Bidders represent and warrant:
- (a) that they have read and understood the Bank’s definition of Prohibited Practices and the sanctions imposed in case Prohibited Practices take place and that they will comply with the rules applicable to those Practices and sanctions;
- (b) that they have not engaged in any Prohibited Practice as set forth herein;

- (c) that they have not misrepresented or concealed any material facts during the procurement or contract negotiation processes or during the performance of the contract;
- (d) that neither they nor their agents, personnel, sub-contractors, sub-consultants directors, officers or principal shareholders have been declared ineligible to be awarded a contract by the Bank or by another International Financial Institution (IFI) with which the Bank may have entered into an agreement for the mutual enforcement of sanctions or have been convicted of an offense involving a Prohibited Practice;
- (e) that none of their directors, officers or principal shareholders has been a director, officer or principal shareholder of any other company or entity that has been declared ineligible to be awarded a contract by the Bank or by another International Financial Institution (IFI) with which the Bank may have entered an agreement for the mutual enforcement of sanctions, or has been convicted of a crime involving a Prohibited Practice;
- (f) that all commissions, agents' fees, facilitating payments or revenue-sharing agreements related to the Bank-financed activities have been disclosed;
- (g) that they acknowledge that the breach of any of these representations may constitute a basis for the adoption by the Bank of one or more of the measures set forth in Clause 3.1 (b)

SECTION VII. SCHEDULE OF REQUIREMENTS

RENDERED

Scope of Work

**Supply, Installation, Commissioning and
Maintenance of CCTV Surveillance
System at the Horizon Adult Remand
Correctional Facility**

Purpose

The Ministry of National Security (MNS), through the Security Strengthening Project (SSP) is seeking the services of a reputed company, for the “Supply, Installation, Commissioning and Maintenance of CCTV Surveillance System at the Horizon Adult Remand Correctional Facility. This document provides information to enable the bidders to understand the broad requirements to submit their bids.

The MNS/SSP/DCS reserves the right to amend/add/delete/edit any of the following items of the scope of work, which shall be binding on the successful bidder.

Background

The MNS/SSP/DCS proposes to procure the CCTV system for the Horizon Adult Remand Correctional Centre for monitoring and surveillance purpose, to include a purpose built monitoring facility at the facility and an off-site secondary monitoring site at the DCS’ Head Office- King Street, Kingston.

Project Objective

The objective of this project is supplying, installing, commissioning and maintenance of CCTV without any damage as per specified configuration in this RFP at Horizon Adult Remand Correctional Centre. The bidder needs to submit the detailed supply and maintenance plan of the CCTV surveillance system. It shall cover the design of IP based surveillance system, supply, installation, commissioning followed by 2 years onsite comprehensive annual maintenance period (@ 6 month intervals).

Supply, Installation, Commissioning & Maintenance of CCTV at the Horizon Adult Remand Correctional Centre

The technical specifications of the above equipment required to be procured and installed are detailed in the **Annex**. These specifications are the **minimum requirements** of the MNS/SSP/DCS. The Bidder can offer higher/latest specifications, or additional cameras [with placement justifications] at the time of submitting proposal.

The make/model of the camera proposed by the bidder **needs to be consistent** throughout the entire period of the contract (to include the warranty and maintenance period). However, if the particular model becomes obsolete and such certificate is produced by the manufacturer with supporting document showing the replacement of the existing model

with new model with higher specifications, the MNS/SSP/DCS may consider replacing the existing model with the newer model.

General Coverage Requirements

- i. Cameras should be installed to provide 100% coverage of the prison facility to include the main road adjacent to facility and entire perimeter.
- ii. Cameras should be able to monitor an inmate from the time he enters through the main gates of the facility, to his cell/holding area.
- iii. Cameras should be able to monitor visitors to the facility from the time they enter, to reaching their place/office of business,
- iv. Areas EXEMPT from coverage:
 - a. Bathrooms
 - b. Inside prison cells (* except medical ward)
 - c. Administrative and duty offices
 - d. Inside Officer's dormitories
 - e. Medical office
- v. Camera/s must be installed along Spanish Town Road to see flow of traffic in easterly and westerly direction (stand-alone pole)
- vi. Each stand-alone pole must have a PTZ installed along with fixed cameras as necessary.
- vii. Each stand-alone pole must be made of galvanized Steel, circle reducing and of height 30feet (**poles may already be installed at facility; bidder must take these into account and indicate where infrastructure will be repurposed and how**).
- Cancelation
- viii. New pole foundations must be 24"x24"x24" with 3000psi concrete aggregate.
- ix. All doorways and hallways must be completely covered.
- x. All staircases must be completely covered.
- xi. All general population areas must be completely covered.
- xii. Outside the Armory must be covered.
- xiii. All parking lots/areas must be covered
- xiv. All recreational areas must be covered (PTZ and fixed cameras)
- xv. All prisoner reception and processing areas must be completely covered.
- xvi. Best efforts should be made for each camera to be able to be seen by another camera and vice versa.

- xvii. Full coverage of delivery bay.
- xviii. Full coverage of prisoner transport bay.
- xix. Galvanized steel pipes and fittings must be used to carry cabling throughout prison. Pipes should be installed in a manner least likely to be accessed by inmates. Where possible, run pipes on outside of cell blocks/building.
- xx. Supply and install anti-vandalism camera cages where required.

Perimeter Coverage

- i. A camera site (up right pole+camera/s) must exist every 60-80 meters along the perimeter wall.
- ii. Poles can be installed in the inside of the perimeter wall and extend 10-15 feet about the perimeter wall.
- iii. Each site must have a minimum of 1-PTZ and 2 fixed cameras (looking in either direction along the wall)
- iv. Additional “in-ward facing “cameras may be required at some sites to cover critical areas on the compound.
- v. The area between the concrete perimeter fence and the chain linked fence must be covered as best as is possible.

Main Gate Coverage

- i. Cameras must be able to capture vehicles entering the roadway to the Facility, entering the facility and to the point of parking, delivering goods, or setting down occupants/prisoners.
- ii. Camera/s must be specifically positioned to capture licence plates entering the facility.
- iii. Camera/s must be specifically positioned to capture the faces of persons entering through the pedestrian gates.
- iv. Camera/s must be specifically positioned to see inside vehicles upon entering/exiting the facility (installed at car window height to allow sentry officer to instruct motorists to wind down windows upon entering/exiting compound. (Ref. JDF’s Main Gate Entrance)

Cell Block Coverage

- i. For security purposes, details of the prison layout will not be made available in this RFP, in this regard, each bidder **MUST** attend specifications walk through on **April 16, 2021**.
- ii. However, consider the **minimum** coverage for EACH block:
 - a. 2 dome cameras on either end of each cell block;
 - b. 2 dome cameras in each security post landing;
 - c. 2 dome cameras in each staircase landing;
 - d. Full staircase coverage
 - e. 4 dome cameras will be needed on the third floor of the cell block.
 - f. Bidders may make proposals to offer maximum coverage, however special consideration should be given to avoid “over-saturation of cameras”.
 - g. Four (4) dome cameras in specialist* cell block

Medical Block Coverage

- i. Dome cameras to be installed on either end of the block;
- ii. Cameras to be installed to see inside ALL cells on the medical ward**.

Monitoring Centre at Horizon Remand Centre

- i. Removal of all furniture from existing room (to be handed over to DCS);
- ii. General refurbishing and repainting of room (to include cable management);
- iii. Installation of second 18,000 BTU air conditioning unit (for redundancy);
- iv. Re-wiring/upgrade of electrical infrastructure to facilitate new equipment;
- v. Supply, installation of ten (10) 55" 24/7 LCDs to be configured as the single display video wall with dynamic display options. **Nb.** 6 LCDs to be installed on the east wall in a 2x3 grid configuration and 4 LCDs to be installed in the south wall in a 2X2 grid configuration. (see specifications)
- vi. South wall currently has louver windows; this would need to be covered with ply/drywall to facilitate installation of LCDS.
- vii. All cabling and electrical wires must be concealed
- viii. LCDS must be mounted using interlocking scissor mounts to be allow for easy maintenance (see specifications).
- ix. Wall behind video walls must be painted black/ other two walls should be refreshed as is coloured now.

- x. Video wall controllers must allow for operator to display a minimum of fifty (50) cameras simultaneously; select varying display grids, and cast as full screen (in ratio) across multiple monitors.
- xi. A 2-tier monitoring console should be installed in room (see specifications)
- xii. Supply and installation of a Server Rack/Utility cabinet (See Specifications)
- xiii. Six (6) 24/7 high back full support chairs to be supplied and installed.
- xiv. Two (2) dome cameras to be installed inside the monitoring room.
- xv. One (1) 60" Office desk to be supplied and installed (for supervisor)
- xvi. UPS system to be appropriately specified and recommended based on calculated electrical load of the items to be quoted.
- xvii. Appropriate NVR to be specified to receive camera feeds (camera feeds must be shared across multiple NVRs as a means of redundancy)
- xviii. Appropriate routing and cable management to be included.
- xix. Each bidder must propose a camera naming protocol and label each cable as such.
- xx. Supply and installation of 40" display (TV or Monitor) to be installed in the Superintendent's office (approx. 200 m from control room) to be connected using HDMI/Ethernet connector and configured to view a minimum of thirty (30) high priority cameras.
- xxi. Supply and installation of a computer room/server room fire suppression system.

DCS Head Office Monitoring Centre

- i. Monitoring centre to be established in existing conference room;
- ii. Six (6) 55" 24/7 LCDs to be supplied and installed in a 2x3 video configuration on the south wall of the room.
- iii. Six (6) interlocking scissor mounts to be supplied and installed.
- iv. Video wall controller to be installed to allow for dynamic viewing.
- v. Necessary equipment to be installed in server room (on third floor) and routed to conference room.
- vi. Concealed cabling
- vii. All electrical outlets for video wall should be concealed behind video wall.
- viii. UPS system to be appropriately specified and recommended based on calculated electrical load of the items to be quoted.
- ix. Access control for door to conference room (+electro mag locks, etc.)

- x. Horizon Adult Remand Centre and DCS's Head Office will be connected via dedicated fibre optic cable; bidders should consider necessary termination equipment at each site to establish link.
- xi. 2 computer workstations to manage video feeds and system

Inter-working of Hardware and Software

The bidder must take necessary steps to successfully install all the items supplied by him at the specified locations.

- i. Design, Supply, Installations, Commissioning and maintenance of high performance IP based video surveillance system including suitable mounting arrangements (such as poles and brackets etc.).
- ii. Laying, terminating & connecting cameras and storage devices with maximum redundancy (redundant paths to still allow for transmission of feeds to the surveillance room if a leg of fibre is damaged) between cameras, storage & control room.

Establishing control room for configuration, operation, monitoring & maintenance with high resolution displays (24/7 usage) and workstations for monitoring purpose has to be setup for configuration of all Cameras. Horizon Adult Remand Correctional Centre will provide place for control room with required basic infrastructure facilities (i.e. Electricity, Network Point etc.). The Bidder shall be responsible for any Interior Work required for the installation purpose. There shall be no additional payment for the same. The LCDs need to be configured as a single display for monitoring all cameras. Required mixers, video wall controllers/connectors etc. should be taken care by the bidder without any additional charge from the quote provided in the financial bid.

- iv. Supply, Installation, configuration & customization of Video Monitoring and Management Software with perpetual license. The software package should be capable to support **ALL** cameras at the same time from the control room **AND** Head Office.
- v. The proposed solution **should not** require proprietary computer, server, and network or storage hardware.
- vi. The proposed solution should maintain the single centralized administration, configuration and authentication database for entire system.

- vii. The network should be designed such that in case there is problem at any of the switch/ node the whole system should not be affected and only that part is affected.
- viii. The proposed CCTV camera should support both fixed IP addresses and dynamically assigned IP addresses provided by a Dynamic Host Control Protocol (DHCP) server.
- iv. The camera shall have an Easy Focus function, which adjusts the camera focus remotely using Graphical User Interface. When the camera is switched between day and night modes, the Easy Focus function is automatically activated to keep the camera focused.
- v. The cameras should be configured for automatic day / night display, so that without manual intervention, camera switches to night mode when the light condition is poor. It shall have provision to change in the day / night mode manually also.
- vi. Should have provision to monitor video feeds on various location and devices as prescribed by the prison department.
- vii. Should have a camera tampering detection function that alerts the operator in control room if the camera is tampered with. Tampering can include spraying the camera lens, covering it with a cloth, or changing the mounting direction.
- viii. Should support IP filtering, whereby access to the camera can be restricted to one or more groups of selected users. Minimum 4 (Four) different groups can be established by defining an IP address range for each group.
- ix. System should allow to configure backup policy of 60 days, which can be expanded as and when required.
- x. There should be no any hidden charges for any hardware/ software requirement for smooth and satisfactory working of the entire CCTV Surveillance system.
- xi. Installation & commissioning Network Video Recorder (NVR) for Digital Video Storage for primary recording, Workstations for secondary video recording for redundancy, Switches, UPS and Weather Proof Panel box for cameras, Laying Power-Over Ethernet (POE) cable and Surge & lightning protection for each camera etc.
- xii. The CAT 6 cable should conform to CAT 6 specifications.
- xiii. Network cabling shall be done using galvanized steel pipes, capping and accessories. The route for cabling should be in areas least, non-accessible by inmates
- xiv. The aesthetic appearance of the cabling within office and other visible areas is to be taken into consideration while planning the cable route.

xv. Cable routes should be planned to avoid fluorescent light fittings and power cables and where they are run parallel to power they must be at least 60mm apart. Crossing power cables is allowed but it must be at right angles, and some form of bridge should be used.

All terminations should be carried out according to the manufacturer's instructions and guidelines, and the standards for generic cabling systems viz. the cable sheath should be stripped back no more than 13mm from the point of termination, the twist rates should be maintained, maximum CAT 6 cable run to be 100 m etc.

xxii. The Successful bidder is responsible for configuration of IP address required for CCTV video feeds.

xxiii. The Successful bidder is responsible for supplying a firewall/network security solution for both the Horizon Monitoring Centre and the DCS's Head Office.

xxiv. The Solution should capture, store, and analyze digital video images to enable central monitoring from Prison.

xxv. Authorized personnel should be able to rapidly focus on images of specific locations, people, and events, anytime and anywhere, without reviewing incalculable hours of video recordings.

xxvi. The system should be provided with weather proof outdoor IP based Camera, lens, housing & mountings to capture video which, would be viewed & controlled through the Video Management Software, recorded and stored. The video management software will be used to configure the Network video recorder, and once installation and setup are complete, the video management server should run seamlessly in the background to manage the connections, access and storage.

xxvii. After commissioning the Video surveillance system, the same shall be demonstrated for all its capabilities to the relevant user department to make them familiar with the system on mutually agreed dates.

xxviii. The video surveillance system should be ONVIF Compliant.

xxix. The proposed surveillance system should include Facial Recognition and Licence Plate Recognition Feature sets.

“Guidelines for implementation of CCTV cameras in the Horizon Adult Remand Centre”

Hardware Warranty

The offer must include **two years 100 % comprehensive on-site warranty** for all the hardware supplied under the scope of this RFP. The 100 % comprehensive on-site warranty would start from single and uniform date, i.e. from the date of commissioning of service.

Hardware Failure

- a) The equipment/goods must conform to the specifications given and of desired quality brand new and without any damages.
- b) Consistency in delivery shall be maintained for the entire lot of products ordered. All the required quantity of equipment/s as per requirement shall be of the same brand and model number. The bidder shall not substitute any internal components or subsystems of the product by similar items of different manufacturer/s.
- c) All the equipment shall be supplied with the relevant interface cables, connectors and necessary standard accessories.
- d) If during the warranty period, any equipment supplied under the scope of this RFP has a hardware failure on four or more occasions in a quarter, it shall be replaced by equivalent new equipment as proposed by the bidder at no cost to the MNS/SSP/DCS

Technical Documentation

The Bidder shall submit the following documentation after installation of all equipment supplied under the scope of this RFP.

- a) Details of Implementation and Maintenance Plan.
- b) Warranty certificate indicating 2 year's onsite comprehensive warranty from the Manufacturer for all the equipment supplied under the scope of this RFP.
- c) Detail Project Plan
- d) Detailed SLA management plan including incident reporting and resolution process
- e) Systems Administration Manuals
- f) Database Administration Manuals
- g) User manuals
- h) Detailed CCTV Surveillance System report
 - Component and equipment list
 - Product description sheets
 - System design drawing(s)

- System schematic diagram(s)
- Complete operation and maintenance instruction manuals

Acceptance Tests/Demonstration

At the discretion of the MNS/SSP/DCS, acceptance tests will be conducted by the bidder at the mentioned site in the presence of the nominated officials. There shall not be any additional charges payable by the MNS/SSP/DCS for carrying out this acceptance test.

Completeness of Installation & Testing

The installation and testing will be deemed as incomplete if system is not operational or not acceptable to the MNS/SSP/DCS after acceptance testing/ examination. Also, the bidder shall have to supply all necessary accessories along with the supplied goods, data sheets and documentation which may be required, whether mentioned or not mentioned in the RFP scope, for successful acceptance of the quoted equipment to the MNS/SSP/DCS. It is the responsibility of the bidders to quote for and provide all the H/w and S/w for meeting all the requirements of the RFP. Additionally, if after the award of contract, it is felt that additional Hardware and Software are required for meeting the RFP requirement and the same has not been quoted by the Successful Bidder, the Successful Bidder shall provide all such additional hardware/software at no additional cost to MNS/SSP/DCS.

Operation and Maintenance for 2 (Two) years

Once the systems have been commissioned and accepted, the Bidder shall maintain the system (Hardware, Software and peripherals) for the period of 2 years from date of acceptance for onsite comprehensive annual maintenance period (CAMC).

- a) It shall involve but not limited to the following activities;
 1. Ensure the desired functioning of the Interface / integration
 2. Software installation and testing whenever required
 3. Provide technical support on system parameters and requirement of Prison Department
 4. Provide handholding support and training services as part of the post implementation services, on a scheduled basis as well as on a need basis.
- b) The comprehensive maintenance and warranty of hardware shall include, but not limited to the following;
 1. In case of failure, the Successful bidder needs to repair or replace the faulty part/component/device to restore the services at the earliest as per defined SLAs.
 2. Delivery/ installation of the store should strictly be completed within the stipulated period of delivery. Any incident during installation will be bidder's risks.

3. The cost of the repairing or replacement of faulty part/component/device has to be entirely borne by the successful bidder.
4. All expenses related to part/component/device, including hiring of specialized technical expertise, in case required, has to be borne by the successful bidder as part of comprehensive maintenance.
5. The Successful bidder also needs to make alternate arrangement in case of major failure happens in the network, due to which services may be effected for longer period.
6. After repairing or replacement of the part/component/device, the successful bidder needs to put the same into operation.
7. The bidder has to submit the Manufacturer authorization for sale, support and service. The equipment/materials should be under warranty for 2 years (on-site) on all material supplied from the date of successful installation and testing. Warranty certificate from Manufacturer should be submitted.

Training

The Bidder shall provide hands on training at Horizon Adult Remand Centre and the DCS' Head Office; related to operation of the surveillance system installed by the bidder. MNS/SSP/DCS will measure the effectiveness after the completion of the training. In case the participants are not satisfied with the training, then MNS/SSP/DCS may ask the successful bidder to conduct refresher training sessions.

Project Timelines

T = Date of Award of contract

Activity/Task	Timeline
Signing of Contract	T
Submission of Project Implementation Plan	T + 3 days
Delivery, Installation and Commissioning and acceptance of CCTV Surveillance System (G)	T + 60days
Operation, Maintenance and Warranty Period (W)	G + 2Years

Each activity/deliverable shall be deemed to be complete only after due diligence and acceptance by the department.

REQUIREMENTS

Outlined below are the requirements gathered by SSP-DCS’s project team. This can be further refined by the vendor.

A detailed description of the essential technical and performance characteristics of each component making up the surveillance system and other requirements must be done in the table below. Commentary on the Purchaser’s Technical Requirements, demonstrates the responsiveness of the system offered to those requirements.

In demonstrating responsiveness, the commentary shall include explicit cross reference to catalogues, technical specifications or other pre-printed materials submitted with the bid.

The **priority** column in the requirements table below is defined as follows:-

C – critical: This feature is a critical and mandatory requirement and bids not offering this feature or its equivalent will be rejected

R – required: This feature is required to support DCS operations but bids will not necessarily be rejected if the feature is not available

D – desired: this feature is not necessarily required to the support DCS operations, but would be a nice feature to have.

Detailed responses may be required for many of the requirement statements in order to fully demonstrate compliance. Without providing sufficient clear detail, Bidders run the risk of their bids being declared non-responsive. In all such cases, a brief response must be provided in the proper order and format which may refer, in a clear and simple manner, to the appropriately labelled detailed information. Reference to this information must be included in the column titled ‘Remarks/Cross Reference’.

NO.	REQUIREMENT	DCS PRIORITY C/R/D	REQ. MET? (Y/N)	HOW REQUIREMENT IS MET REMARKS/CROSS REFERENCE
GENERAL COVERAGE REQUIREMENTS				
1	Cameras should be installed to provide 100% coverage of the prison facility to include the main road adjacent to facility and entire perimeter.	C		
2	Cameras should be able to monitor an inmate from the time he enters through the main gates of the facility, to his cell/holding area.	C		
3	Cameras should be able to monitor visitors to the facility from the time they enter, to reaching their place/office of business,	C		

NO.	REQUIREMENT	DCS PRIORITY C/R/D	REQ. MET? (Y/N)	HOW REQUIREMENT IS MET REMARKS/CROSS REFERENCE
4	Areas EXEMPT from coverage: a) Bathrooms b) Inside prison cells (* except medical ward) c) Administrative and duty offices d) Inside Officer's dormitories e) Medical office	R		
5	Camera/s must be installed along Spanish Town Road to see flow of traffic in easterly and westerly direction (stand-alone pole)	C		
6	Each stand-alone pole must have a PTZ installed along with fixed cameras as necessary.	C		
7	Each stand-alone pole must be made of galvanized Steel, circle reducing and of height 30feet (poles may already be installed at facility; bidder must take these into account and indicate where infrastructure will be repurposed and how). Cancelation	C		
8	New pole foundations must be 24"x24"x24" with 3000psi concrete aggregate.	C		
9	All doorways and hallways must be completely covered.	C		
10	All staircases must be completely covered.	C		
11	All general population areas must be completely covered.	C		
13	Outside the Armory must be covered.	C		
14	All parking lots/areas must be covered	C		
15	All recreational areas must be covered (PTZ and fixed cameras)	C		
16	All prisoner reception and processing areas must be completely covered.	C		

NO.	REQUIREMENT	DCS PRIORITY C/R/D	REQ. MET? (Y/N)	HOW REQUIREMENT IS MET REMARKS/CROSS REFERENCE
17	Best efforts should be made for each camera to be able to be seen by another camera and vice versa.	R		
18	Full coverage of delivery bay.	C		
19	Full coverage of prisoner transport bay.	C		
20	Galvanized steel pipes and fittings must be used to carry cabling throughout prison. Pipes should be installed in a manner least likely to be accessed by inmates. Where possible, run pipes on outside of cell blocks/building.	C		
21	Supply and install anti-vandalism camera cages where required.	C		
PERIMETER COVERAGE				
	REQUIREMENT	DCS PRIORITY C/R/D	REQ. MET? (Y/N)	HOW REQUIREMENT IS MET/REMARKS/CROSS REFERENCE
22	A camera site (up right pole+camera/s) must exist every 60-80 meters along the perimeter wall.	C		
23	Poles can be installed in the inside of the perimeter wall and extend 10-15 feet about the perimeter wall.	D		
24	Each site must have a minimum of 1-PTZ and 2 fixed cameras (looking in either direction along the wall)	C		
25	Additional "in-ward facing" cameras may be required at some sites to cover critical areas on the compound.	R		
26	The area between the concrete perimeter fence and the chain linked fence must be covered as best as is possible.	D		
MAIN GATE COVERAGE				
	REQUIREMENT	DCS PRIORITY C/R/D	REQ. MET? (Y/N)	HOW REQUIREMENT IS MET REMARKS/CROSS REFERENCE

NO.	REQUIREMENT	DCS PRIORITY C/R/D	REQ. MET? (Y/N)	HOW REQUIREMENT IS MET REMARKS/CROSS REFERENCE
27	Cameras must be able to capture vehicles entering the roadway to the Facility, entering the facility and to the point of parking, delivering goods, or setting down occupants/prisoners.	C		
29	Camera/s must be specifically positioned to capture licence plates entering the facility.	C		
30	Camera/s must be specifically positioned to capture the faces of persons entering through the pedestrian gates.	C		
31	Camera/s must be specifically positioned to see inside vehicles upon entering/exiting the facility (installed at car window height to allow sentry officer to instruct motorists to wind down windows upon entering/exiting compound. (Ref. JDF's Main Gate Entrance)	R		
CELL BLOCK COVERAGE				
	REQUIREMENT	DCS PRIORITY C/R/D	REQ. MET? (Y/N)	HOW REQUIREMENT IS MET REMARKS/CROSS REFERENCE
32	The minimum coverage for EACH block:	C		
	2 dome cameras on either end of each cell block;			
	2 dome cameras in each security post landing;			
	2 dome cameras in each staircase landing;			
	Full staircase coverage			
	4 dome cameras will be needed on the third floor of the cell block.			
	Bidders may make proposals to offer maximum coverage, however special consideration should be given to avoid "over-saturation of cameras".			
	Four (4) dome cameras in specialist* cell block			

NO.	REQUIREMENT	DCS PRIORITY C/R/D	REQ. MET? (Y/N)	HOW REQUIREMENT IS MET REMARKS/CROSS REFERENCE
MEDICAL BLOCK COVERAGE				
	REQUIREMENT	DCS PRIORITY C/R/D	REQ. MET? (Y/N)	HOW REQUIREMENT IS MET REMARKS/CROSS REFERENCE
33	Dome cameras to be installed on either end of the block;	C		
34	Cameras to be installed to see inside ALL cells on the medical ward**.	C		
TRAINING REQUIREMENTS, MAINTENANCE, AND WARRANTY				
	REQUIREMENT	DCS PRIORITY C/R/D	REQ. MET? (Y/N)	HOW REQUIREMENT IS MET REMARKS/CROSS REFERENCE
35	Labour 2 Years - all Cameras Quarterly Maintenance	C		
36	2 year warranty on all hardware	C		
37	Training	C		
FIRE SUPPRESSION SYSTEM				
	REQUIREMENT	DCS PRIORITY C/R/D	REQ. MET? (Y/N)	HOW REQUIREMENT IS MET REMARKS/CROSS REFERENCE
38	Supply MS 2 fire alarm panel	R		
39	Supply electrical smoke detector	R		
40	To supply pull station	R		
41	Supply horn & strobe	R		
42	Supply piping, fittings and hardware	R		
43	Supply Fire Resistant Cable 4 Core (1000ft)	R		
44	To commission system and install materials	R		
45	Supply 10lb Carbon Dioxide Fire Extinguisher	R		
MONITORING CENTRE AT HORIZON REMAND CENTRE				
	REQUIREMENT	DCS PRIORITY C/R/D	REQ. MET? (Y/N)	HOW REQUIREMENT IS MET REMARKS/CROSS REFERENCE

NO.	REQUIREMENT	DCS PRIORITY C/R/D	REQ. MET? (Y/N)	HOW REQUIREMENT IS MET REMARKS/CROSS REFERENCE
46	Removal of all furniture from existing room (to be handed over to DCS);	R		
47	General refurbishing and repainting of room (to include cable management);	R		
48	Installation of second 18,000 BTU air conditioning unit (for redundancy);	C		
49	Re-wiring/upgrade of electrical infrastructure to facilitate new equipment;	C		
50	Supply, installation of ten (10) 55" 24/7 LCDs to be configured as the single display video wall with dynamic display options. Nb. 6 LCDs to be installed on the east wall in a 2x3 grid configuration and 4 LCDs to be installed in the south wall in a 2X2 grid configuration. (see specifications)	C		
51	South wall currently has louver windows; this would need to be covered with ply/drywall to facilitate installation of LCDS.	C		
52	All cabling and electrical wires must be concealed	C		
53	LCDS must be mounted using interlocking scissor mounts to be allow for easy maintenance (see specifications).	R		
54	Wall behind video walls must be painted black/ other two walls should be refreshed as is coloured now.	R		
55	Video wall controllers must allow for operator to display a minimum of fifty (50) cameras simultaneously; select varying display grids, and cast as full screen (in ratio) across multiple monitors.	C		
56	A 2-tier monitoring console should be installed in room (see specifications)	C		

NO.	REQUIREMENT	DCS PRIORITY C/R/D	REQ. MET? (Y/N)	HOW REQUIREMENT IS MET REMARKS/CROSS REFERENCE
57	Supply and installation of a Server Rack/Utility cabinet (See Specifications)	C		
58	Six (6) 24/7 high back full support chairs to be supplied and installed.	R		
59	Two (2) dome cameras to be installed inside the monitoring room.	C		
60	One (1) 60" Office desk to be supplied and installed (for supervisor)	R		
61	UPS system to be appropriately specified and recommended based on calculated electrical load of the items to be quoted.	C		
62	Appropriate NVR to be specified to receive camera feeds (camera feeds must be shared across multiple NVRs as a means of redundancy)	C		
63	Appropriate routing and cable management to be included.	C		
64	Each bidder must propose a camera naming protocol and label each cable as such.	C		
65	Supply and installation of 40" display (TV or Monitor) to be installed in the Superintendent's office (approx. 200 m from control room) to be connected using HDMI/Ethernet connector and configured to view a minimum of thirty (30) high priority cameras.	R		
66	Firewall/network security solution	C		
DCS HEAD OFFICE MONITORING CENTRE				
	REQUIREMENT	DCS PRIORITY C/R/D	REQ. MET? (Y/N)	HOW REQUIREMENT IS MET REMARKS/CROSS REFERENCE
67	Monitoring centre to be established in existing conference room;	C		
68	ii. Six (6) 55" 24/7 LCDs to be supplied and installed in a 2x3 video configuration on the south wall of the room.	C		

NO.	REQUIREMENT	DCS PRIORITY C/R/D	REQ. MET? (Y/N)	HOW REQUIREMENT IS MET REMARKS/CROSS REFERENCE
69	Six (6) interlocking scissor mounts to be supplied and installed.	C		
70	Video wall controller to be installed to allow for dynamic viewing.	C		
71	Necessary equipment to be installed in server room (on third floor) and routed to conference room.	C		
72	Concealed cabling	R		
73	All electrical outlets for video wall should be concealed behind video wall.	C		
74	UPS system to be appropriately specified and recommended based on calculated electrical load of the items to be quoted.	C		
75	Access control for door to conference room (+electro mag locks, etc.)	R		
76	Horizon Adult Remand Centre and DCS's Head Office will be connected via dedicated fibre optic cable; bidders should consider necessary termination equipment at each site to establish link.	C		
77	Firewall/network security solution	C		
78	2 computer workstations to manage video feeds and system	C		

Key

<i>Critical</i>	<i>This feature is a critical and mandatory requirement and bids not offering this feature or its equivalent will be rejected</i>
<i>Required</i>	<i>This feature is required to support DCS operations but bids will not necessarily be rejected if the feature is not available</i>
<i>Desired</i>	<i>This feature is not necessarily required to support the DCS operations but would be a nice feature to have</i>

TECHNICAL SPECIFICATIONS

CCTV Hardware and Peripheral

As part of technical proposal the bidder shall submit the technical compliance in respect of products on the **Manufacturer/ Bidders letter head duly signed and stamped by the authorized signatory**. *The MNS/SSP/DCS reserves the right to contact authorized signatory to establish correctness of the contents of the submitted documents and seek documentary evidence.*

Below mentioned are the minimum technical specifications required. The bidder must submit all related certificates, brochures and compliance related documents. All compliance related documents and certifications submitted should be for the specific model proposed, quoted and to be supplied.

Bidder shall also submit un priced BOM with any additional item quoted in their financial bid.

Table of Quantities- Minimum Specification

No.	Supplies	Required Quantity
1	2 MP PTZ Cameras	To be specified
2	2 MP Indoor Dome Cameras	To be specified
3	2 MP Varifocal Outdoor Fixed/Bullet cameras	To be specified
4	55 inch 4K 2.5 mm bezel 24/7 LCD	16
5	Interlocking scissor mounts	16
6	4K/60 6x6 HDMI Matrix Switcher (video wall controller)	2
7	Dell OptiPlex Windows 10, Core 2 Duo 3.0GHz, 8GB, 1TB, with 22" LCD	8
8	DTK – 120S 15A ‘Critical Load’ Surge Protector	4
9	Uninterrupted Power Supply (As required)	2
10	60 amp Double Throw Safety Switch	2
11	42U Server rack Enclosure (vented shelves)	1
12	USB Joystick	3
13	Biometric Access control system (with access control administrator and management software and paraphernalia)	1
14	No Touch exit buttons	2
15	Electro Magnetic Door Locks	1
16	Magnetic Lock Brackets	1
18	Cat 6 cable (As required)	
19	Installation services- All Equipment and devices	1
20	Training (of all systems)	1
21	2 year Warranty (on all devices and equipment)	1
22	2-Tier Monitoring/dispatch Console	1
23	24/7 Full support monitoring chairs	1

Technical Specification for PTZ outdoor camera-2MP

Proposed Brand _____ (Please Specify)

Proposed Make/Model _____ (Please Specify)

SN	Parameter	Specification	Proposed Specification
1	Image Sensor	4 Megapixel progressive scan CMOS or better	
2	Scanning System	Progressive	
3	Electronic Shutter Speed	Minimum / Maximum / Anti flicker	
4	Minimum Illumination	Color : 0.05Lux (30IRE), B/W : 0Lux (IR LED on)	
5	IR Distance	Distance up to100m	
6	IR On/Off Control	Auto/ Manual	
7	Lens Type	PTZ- angle of view 2.0°-59.8°/ tilt range 25°-90° (auto-flip)	
8	Focal Length	4 mm or greater , electronic image stabilizer – Zoom – 36X	
9	Video Compression	H.264	
10	Resolution	1080P(1920x1080)/1.3M(1280x960)/720P(1280x720)/VGA(640x480)	
11	Bit Rate Control	CBR/VBR	
12	Day/Night	Auto(ICR) / Color / B/W	
13	BLC Mode	BLC / HLC / WDR(100dB)	
14	White Balance	Auto / Natural / Outdoor / Manual	
15	Gain Control	Auto/Manual	
16	Noise Reduction	3D DNR	
17	Motion Detection	Off / On (4 Zone, Rectangle)	
18	Region Interest	Off / On (4 Zone)	
19	Smart IR	Support	
20	Mirror	Off / On	
21	Privacy Masking	Off / On (4 Area, Rectangle)	
22	Ethernet	RJ-45 (10/100Base-T),	
23	Protocol	HTTP; HTTPs; TCP; ARP; RTSP; RTP; UDP; SMTP; DHCP; DNS; DDNS; PPPOE; IPv4/v6; QoS; UPnP; NTP; 802.1x; Multicast; ICMP; IGMP	
24	Streaming Method	Unicast / Multicast	
25	Edge Storage	Support Up To Micro SD card 128GB	
26	Certifications	UL/CE, FCC, IEC/EN	
27	Audio Interface	1/1 channel In/Out	
28	Alarm	1 channel In, 1 channel Out	
29	Power Supply	24VAC power adaptor or High POE injector	
30	Operating Conditions	0°C ~ +50°C	
31	Interoperability	ONVIF	
32	Storage Conditions	0°C ~ +50°C	

Technical Specification for Varifocal Outdoor Bullet Camera-2 MP

Proposed Brand- _____ (Please Specify)

Proposed Make/Model- _____ (Please Specify)

SN	PARAMETER	SPECIFICATION	PROPOSED SPECIFICATIONS
1	Image Sensor	2 Megapixels 1/2.8" CMOS or better	
2	Scanning System	Progressive	
3	Minimum Illumination	Color : 0.05 Lux , B/W : 0Lux (IR LED on)	
4	S/N Ratio	More than 50dB	
5	IR Distance	Distance up to 30m	
6	IR On/Off Control	Auto/ Manual	
7	Lens Type	Motorized/ Auto Iris(DC)	
8	Max. Aperture	F2.2	
9	Focal length	2.8mm~12mm	
10	Focus Control	Motorized	
11	Close Focus Distance	0.3m	
12	Video Compression	H.264	
13	Streaming Capability	3 Streams	
14	Resolution	1080P(1920x1080)/1.3M(1280x960)/720P(1280x720)/VGA(640x480)	
15	Day/Night	Auto(ICR) / Color / B/W	
16	BLC Mode	BLC / HLC / WDR(100dB)	
17	Gain Control	Auto/Manual	
18	Noise Reduction	3D DNR	
19	Motion Detection	Off / On	
20	Region of Interest	Off / On	
21	Smart IR	Support	
22	Digital Zoom	10x	
23	Mirror	Off / On	
24	Privacy Masking	Off / On	
25	Ethernet	RJ-45 (10/100Base-T) HTTP; HTTPs; TCP; ARP; RTSP; RTP; UDP; SMTP;	
26	Protocol	DHCP; DNS; DDNS; PPPOE; IPv4/v6; QoS; UPnP; NTP; 802.1x; Multicast; ICMP; IGMP	
27	Interoperability	ONVIF	
28	Streaming Method	Unicast / Multicast	
29	Edge Storage	Support Up to Micro SD card 128GB	
30	Certifications	UL/CE, FCC, IEC/EN	
31	Audio Interface	1/1 channel In/Out	
32	Alarm	1/1 channel In/Out	
33	Power Supply	DC12V, PoE (802.3af)(Class 0)	
34	Operating Conditions	0°C ~ +50°C	
35	Storage Conditions	0°C ~ +50°C	
36	Ingress Protection	IP66	
37	Vandal Resistance	IK10	

Technical Specification for Dome Camera-2 MP Indoor

Proposed Brand- _____ (Please Specify)

Proposed Make/Model- _____ (Please Specify)

SN	Parameter	Specification	Proposed Specification
1	Image Sensor	1/2.8" 2 Megapixel progressive scan CMOS or better	
2	Scanning System	Progressive	
3	Electronic Shutter Speed	Minimum / Maximum / Anti flicker	
4	Minimum Illumination	Color : 0.05Lux (30IRE), B/W : 0Lux (IR LED on)	
5	IR Distance	Distance up to 20m	
6	IR On/Off Control	Auto/ Manual	
7	Lens Type	Fixed	
8	Focal Length	2.8 mm	
9	Video Compression	H.264	
10	Resolution	1080P(1920x1080)/1.3M(1280x960)/720P(1280x720)/VGA(640x480)	
11	Bit Rate Control	CBR/VBR	
12	Day/Night	Auto(ICR) / Color / B/W	
13	BLC Mode	BLC / HLC / WDR(100dB)	
14	White Balance	Auto / Natural / Outdoor / Manual	
15	Gain Control	Auto/Manual	
16	Noise Reduction	3D DNR	
17	Motion Detection	Off / On (4 Zone, Rectangle)	
18	Region Interest	Off / On (4 Zone)	
19	Smart IR	Support	
20	Mirror	Off / On	
21	Privacy Masking	Off / On (4 Area, Rectangle)	
22	Ethernet	RJ-45 (10/100Base-T),	
23	Protocol	HTTP; HTTPS; TCP; ARP; RTSP; RTP; UDP; SMTP; IPv4/v6; Multicast; ICMP; IGMP	
24	Streaming Method	Unicast / Multicast	
25	Edge Storage	Support Up To Micro SD card 128GB	

26	Certifications	UL/CE, FCC, IEC/EN	
27	Audio Interface	1/1 channel In/Out	
28	Alarm	1 channel In, 1 channel Out	
29	Power Supply	DC12V, PoE (802.3af)(Class 0)	
30	Operating Conditions	0°C ~ +50°C	
31	Interoperability	ONVIF	
32	Storage Conditions	0°C ~ +50°C	
33	Ingress Protection	IP66	
34	Vandal Resistance	IK10	

Technical Specification for CCTV Controller (NVR)

Proposed Brand- _____ (Please Specify)

Proposed Make/Model- _____ (Please Specify)

SN	Parameter	Specification	Proposed Specification
1	Main Processor	Suitable for taking load of 64 IP cameras @ 1920 x 1080 resolution	
2	Operating System	Embedded LINUX	
3	IP Camera Input	64 Channel	
4	Interface	The proposed solution should have Minimum 2 HDMI and 1 VGA (RS232) port.	
5	Resolution	1920 × 1080 , 1280 × 1024, 1280 × 720 , 1024 × 768	
6	Multi-screen Display	The proposed solution should support local and remote access to display and should support the following 1/4/8/9/16/25/36 screen counts.	
7	On screen display	Camera title, Time, Video loss, Camera lock, Motion detection, Recording	
8	Compression	The proposed solution should support at least H.264, MPEG, and compression technique	
9	Resolution	12MP, 8MP, 6MP, 5MP, 4MP, 3MP, 1080P, 1.3MP, 720P etc.	
10	Record Rate	384 Mbps	
11	Bit Rate	16Kbps ~ 20Mbps Per Channel	
12	Record Mode	Manual, Scheduled , Event (Pre & Post)	
13	Alarm input	4 Channel,	
14	Relay Output	4 Channel, NO/NC Programmable,	
15	Playback	Minimum 8 Channels synchronize play back	
16	Backup Mode	The proposed solution should support any one USB Device/Network/E-SATA of the backup mode.	
17	Network Interface	The proposed solution should have minimum of 2 RJ-45 Ports which 10/100/1000Mbps. 2 SFP ports can be optional.	
18	Network Function	HTTP, HTTPs, TCP/IP, IPv4/IPv6, UPnP, RTSP, UDP, SMTP, NTP, DHCP, DNS, IP Filter, PPPoE, DDNS, Alarm Server, IP Search	

19	Interoperability	ONVIF compliant	
20	Internal HDD Slots	Should support at least 96 TB with any no. of slots	
21	HDD Mode	Raid 5-6	
22	Power Supply	The proposed solution should have dual power supply and should support the following specs. 100 ~ 240V AC \pm 10%, 50/60Hz, 3 ~ 1.5A	
23	Operating Conditions	0°C ~ +50°C	
24	Installation	Rack-mounted	
25	Certifications	CE and FCC	

Technical Specification of L2 Switch (PoE Switch)

Proposed Brand- _____ (Please Specify)

Proposed Make/Model- _____ (Please Specify)

SN	Parameter	Specification	Proposed Specification
1	Port	Switch should have 16 Ethernet Port which support 10/100/1000 Mbps ports and additional 2 numbers of fiber uplinks, which support both 1 GE and 10GE.	
	Switch Type	Layer 2 switch	
2	Backplane	Backplane Capable of providing wire-speed switching	
3	Throughput Port Features	500 Mpps or Better Port must support Port Mirroring, Port Trunking and 802.3ad LACP Link Aggregation port trunks	
4	Flow Control	Should Support IEEE 802.3x flow control for full-duplex mode ports	
5	Protocol	<p>The Switch should support 802.1D, 802.1S, 802.1w, Rate limiting</p> <p>The Switch should support 802.1X Security standards</p> <p>The Switch should support 802.1Q VLAN encapsulation, IGMP v1, v2 and v3 snooping ,</p> <p>The Switch should support 802.1p Priority Queues, port mirroring, DiffServ;</p> <p>The Switch should support DHCP;</p> <p>The Switch should support up to 1024 VLANs;</p> <p>The Switch should support IGMP Snooping and IGMP Querying;</p> <p>The Switch should support Multicasting;</p> <p>The Switch must support for TCP/IP;</p> <p>The Switch must have support for integration of data and voice services;</p> <p>The Switch should support IPV4, IPV6;</p> <p>The Switch should support Loop protection and Loop detection;</p> <p>The Switch should support Ring protection.</p>	
6	Security features	<p>The Switch should support 802.1x (Port based network access control);</p> <p>The Switch should support for MAC filtering.</p> <p>The Switch should support TACACS+ and RADIUS authentication;</p> <p>The Switch should support 802.1Q Tagged VLAN and port based VLANs and Private VLAN;</p>	

		<p>The Switch should support dynamic VLAN Registration or equivalent;</p> <p>The Switch should support Dynamic Trunking protocol or equivalent;</p> <p>The Switch should support Network Time Protocol or equivalent Simple Network Time Protocol</p>	
7	Traffic Control Protocol	<p>The Switch should support traffic segmentation; Traffic classification should be based on user-definable application types: TOS, DSCP, Port based, TCP/UDP port number;</p> <p>The switch should support a console port for management via a console terminal or PC;</p> <p>The switch must have support SNMP v1,v2 and v3;</p> <p>The switch should support 4 groups of RMON</p>	
8	Management	<p>The switch should have accessibility using Telnet, SSH, Console access, easier software upgrade through network using TFTP etc. Configuration management through CLI, GUI based software utility and using web interface.</p>	
9	Operating Temperature	0°C ~ +50°C	

Technical Specification for Shield Twisted Pair Ethernet Cable

Proposed Brand _____ (Please Specify)

Proposed Make/Model _____ (Please Specify)

SN	Parameter	Specification	Proposed Specification
1	Conductor Material	Copper	
2	ANSI/TIA Category	6	
3	Cable Type	STP (shielded)	
4	Pairs, quantity	4	
5	Bandwidth support	10/100/1000 Mbps	

Technical Specification for Pipes, Conduit and Poles

The minimum requirement for Pipes, Conduit and Poles is as follows;

GI Pipe	PVC Conduit	CCTV Pole	HDPE Pipe
<input type="checkbox"/> Galvanized Iron <input type="checkbox"/> Class A <input type="checkbox"/> 42 mm OD <input type="checkbox"/> 2 mm Thick <input type="checkbox"/> 6 mtr Length	<input type="checkbox"/> 22 mm <input type="checkbox"/> With required accessories	<input type="checkbox"/> 6Mtr Pole (7 Mts Long) <input type="checkbox"/> Bottom 114 mm OD, 4.5 mm Thick <input type="checkbox"/> Middle 88.9 OD, 4 mm Thick <input type="checkbox"/> Base Size : 350 mm x 350 mm x 16 mm <input type="checkbox"/> With required foundation	<input type="checkbox"/> Double Coated <input type="checkbox"/> Smooth Finishing <input type="checkbox"/> 27 mm ID x 32 mm OD

55" LCDs

- 24/7 Display Monitors
- 4K Input Capable
- Monitor w/LED Back Lighting
- 3.5 mm Bezel to Bezel Width,
- Internal Video Processor Allows 4K Content to be Display
- Across 2x2 Monitor Configuration, Internal scaler allows the spread of 1 image across up to a 15x15 display configuration
- RS-232 Control Management S/W,
- Display Port (1.2) In 1, HDMI (1.4) In 1, Out 1, RS-232C in 1 / Out 1



Interlocking scissor mounts

- Display Range - 45" ~ 80"
- Weight Capacity- 154 lbs / 70 kg
- Height Adjustment- 0.98" / 25 mm
- Depth Adjustment- 0.78" / 20 mm
- Tilt- 2° ~ 4° (Vertical) / ± 3° (Horizontal)
- Mounting Pattern Type- Universal
- Mounting Patterns- 200 x 200 (Min), 400 x 200 (Max) mm

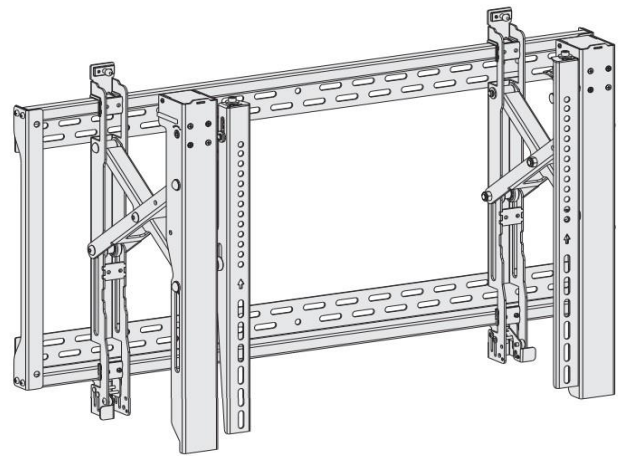

4K/60 6x6 HDMI Matrix Switcher (video wall controller)



- Technical
 - HDMI Compliance: HDMI 2.0b
 - HDCP Compliance: HDCP 2.2 and HDCP 1.4
 - Video Bandwidth: Up to 18 Gbps
 - Video Resolutions: up to 4K2K@50/60Hz(YUV4:4:4),4K2K@30Hz,1080P@120Hz,and 1080P 3D@60Hz
 - Color Space: RGB, YCbCr 4:4:4, YCbCr 4:2:2
 - Color Depth: 10-bit, 12-bit:

- HDMIAudio Formats (Pass-through): LPCM 2/5.1/7.1CH, Dolby Digital, DTS 5.1, Dolby Digital+, Dolby TrueHD, DTS-HD Master Audio, Dolby Atmos, DTS:x
- Audio Formats (Optical/Coaxial In): LPCM 2/5.1/7.1CH, Dolby Digital, DTS 5.1, Dolby Digital+
- Audio Formats (Analog/Coaxial Out): LPCM 2CH up to 192KHz sample rate
- L/R Audio Formats: Analog Stereo 2CH
- Infrared Frequency: 20KHz - 60KHz
- ESD Protection: Human body model $\pm 8\text{kV}$ (air-gap discharge) & $\pm 4\text{kV}$ (contact discharge)
- Connections
 - Inputs:
 - 6x HDMI Type A [19-pin female]
 - 2x L/R Audio In [3.5mm Stereo Mini-jack]
 - 2x Optical Audio In [S/PDIF]
 - 2x Coaxial Audio In[S/PDIF]
 - Bx IR In [3.5mm Stereo Mini-jack]
 - 4x RS-232 [3pin Phoenix Jack]
 - 1x TCP/IP[RJ45]
 - Outputs
 - 2x HDMI Type A [19-pin female]
 - 4x HDBaseT Out [RJ45]
 - 6x L/R Audio Out [3.5mm Stereo Mini-jack]
 - 6x Optical Out [S/PDIF]
 - 7x IR Out[3.5mm Stereo Mini-jack]
- Mechanical
 - Housing: Metal Enclosure
 - Color: Black
 - Dimensions: 483mm[W]x303mm[D]x44.5 mm [H]
 - Weight: 2110g
 - Power Supply: Input: AC100 - 240V 50/60Hz
 - Power Consumption: 60W (Max)
 - Operation Temperature: 32 - 104°F I 0 - 40°C
 - Storage temperature: -4 - 140°F I -20 - 60°C
 - Relative Humidity: 20 - 90% RH (no condensation)

Dell OptiPlex Windows 10, Core 2 Duo 3.0GHz, 8GB, 1TB, with 22" LCD

- Screen Size- 22 inches
- Processor- 3 GHz Intel Core 2 Duo
- RAM- 8 GB 8GB SDRAM DDR3
- Memory Speed-3 GHz
- Hard Drive- 1 TB
- Graphics Coprocessor - Intel Integrated Graphics



Uninterrupted Power Supply System

Input

Nominal Input Voltage: 208-240

Voltage Range: 176-300VAC

Input Frequency: 46 / 64Hz

Output

Nominal Output Voltage: 110-120 / 220-240

Output Frequency: 50 / 60Hz

Number of Outlets: Terminal Block

Surge- only outlets: No

Batt./AVR/ Surge protected outlets: Terminal Block

Protection

AVR: $\pm 3\%$

Surge Energy Rating (Joules): No

Battery: 20x12v / 9AH

Dateline Protection: RJ-45/11



Administration

Monitoring software: (to be specified)

Communication port: USB + RS-232 Port for optional SMNP card

Double Throw Safety Switch



- 60 Amp, 3 phase, 3 pole, 3 wire, non-fusible
- Quick-make and break switching action
- Double break visible blade design
- Highly visible on/off indication
- Modular design
- Front removable lugs
- Defeatable dual cover interlock
- All copper current carrying parts
- Tangential knockouts
- Handle is “pad-lockable” in off position
- NEMA type 1 rating

42U Server rack Enclosure

- Static load capacity: 2500 lbs
- Height: 78.7" (1999mm)
- Width: 23.8" (605mm)
- Depth: 42.1" (1070mm)
- Weight: 298 lbs (135 kg)
-

Rack Compatible Dimensions:

- Width: EIA Standard 19" Rack Rails
- External Width: 23.6" - 600 mm
- Height: 78.74" - 2,000 mm
- Rack Units: 42U
- Depths: 39.37" & 41.34"
-

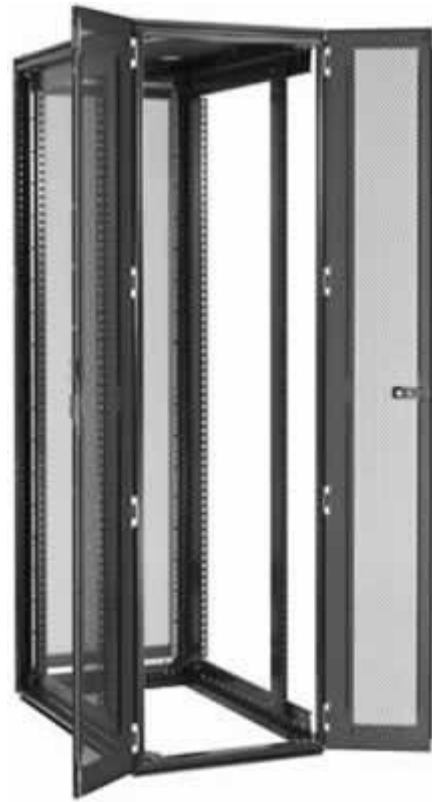

USB Joystick



- Power Supply and Communication by USB Port Directly
- 3D PTZ Control and 2 Joystick Control Buttons
- 10 or more Programmable Buttons
- Supports Digital Tube to Display the Input Content
- Indicators Show Keyboard's Operation Status
- Compatible with Various Client and Platform Software
- Supports USB HID Protocol

Biometric Access Control

- biometric (fingerprint) readers are to be supplied
 - Main Door
- Network devices
- Management Software
- Magnetic door locks and door closers
- Buzzer/call button
-

2-Tier Monitoring/dispatch Console

- Colour- Black
- Height – Adjustable
- Length- 80-100 inches



HARC Monitoring Centre Proposed Design

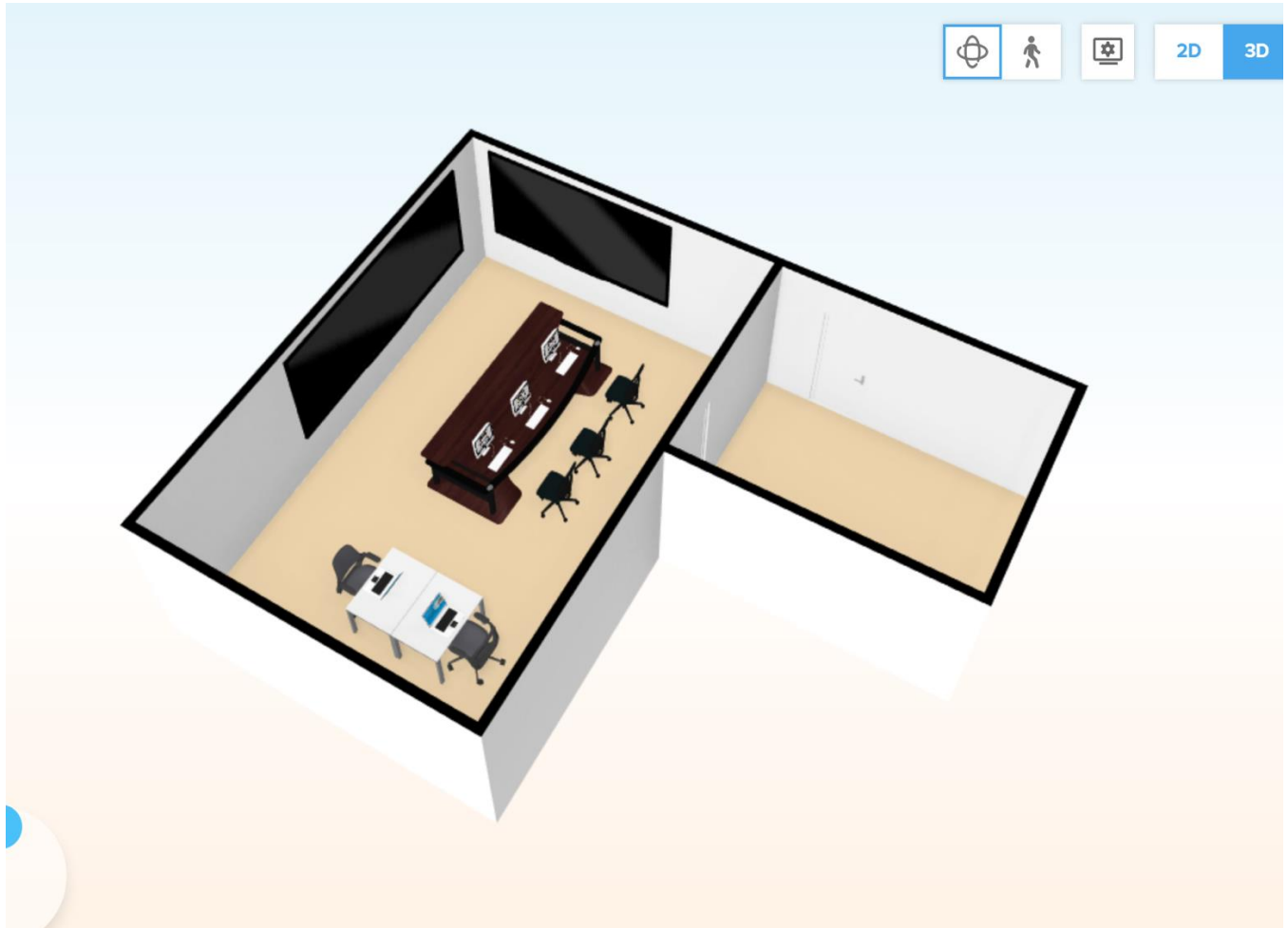

List of Goods and Delivery Schedule

[The Purchaser shall fill in this table, with the exception of the column "Bidder's offered Delivery date" to be filled by the Bidder]

Line Item N°	Description of Goods	Quantity	Physical unit	Named place of Destination as specified in BDS	Delivery (as per Incoterms) Date		
					Earliest Delivery Date	Latest Delivery Date	Bidder's offered Delivery date <i>[to be specified by the bidder]</i>
<i>[insert item No]</i>	<i>[insert description of Goods]</i>	<i>[insert quantity of item to be supplied]</i>	<i>[insert physical unit for the quantity]</i>	<i>[insert named place of destination]</i>	<i>[insert the number of days following the date of effectiveness the Contract]</i>	<i>[insert the number of days following the date of effectiveness the Contract]</i>	<i>[insert the number of days following the date of effectiveness the Contract]</i>

List of Related Services and Completion Schedule

[This table shall be filled in by the Purchaser. The Required Completion Dates should be realistic, and consistent with the required Goods Delivery Dates (as per Incoterms)]

Service	Description of Service	Quantity¹	Physical Unit	Place where Services shall be performed	Final Completion Date(s) of Services
<i>[insert Service No]</i>	<i>[insert description of Related Services]</i>	<i>[insert quantity of items to be supplied]</i>	<i>[insert physical unit for the items]</i>	<i>[insert name of the Place]</i>	<i>[insert required Completion Date(s)]</i>

PART III CONTRACT

SECTION VIII. GENERAL CONDITIONS OF CONTRACT

1. Definitions

- 1.1 The following words and expressions shall have the meanings hereby assigned to them.
- (a) “Bank” means the Inter-American Development Bank (IDB) or any fund administered by the Bank.
 - (b) “Contract” means the Contract Agreement entered into between the Purchaser and the Supplier, together with the Contract Documents referred to therein, including all attachments, appendices, and all documents incorporated by reference therein.
 - (c) “Contract Documents” means the documents listed in the Contract Agreement, including any amendments thereto.
 - (d) “Contract Price” means the price payable to the Supplier as specified in the Contract Agreement, subject to such additions and adjustments thereto or deductions therefrom, as may be made pursuant to the Contract.
 - (e) “Day” means calendar day.
 - (f) “Completion” means the fulfillment of the Related Services by the Supplier in accordance with the terms and conditions set forth in the Contract.
 - (g) “GCC” means the General Conditions of Contract.
 - (h) “Goods” means all of the commodities, raw material, machinery and equipment, and/or other materials that the Supplier is required to supply to the Purchaser under the Contract.
 - (i) “Purchaser’s Country” is the country specified in the Special Conditions of Contract (SCC).
 - (j) “Purchaser” means the entity purchasing the Goods and Related Services, as specified in the SCC.
 - (k) “Related Services” means the services incidental to the supply of the goods, such as insurance, installation, training and initial maintenance and other such obligations of the Supplier under the Contract.
 - (l) “SCC” means the Special Conditions of Contract.
 - (m) “Subcontractor” means any natural person, private or government entity, or a combination of the above, to whom any part of the Goods to be supplied or execution of any part of the Related Services is subcontracted by the Supplier.
 - (n) “Supplier” means the natural person, private or government entity, or a combination of the above, whose bid to perform the Contract has been accepted by the Purchaser and is named as such in the Contract Agreement.

(o) “The Project Site,” where applicable, means the place named in the **SCC Source of Funds**

2. Contract Documents

2.1 Subject to the order of precedence set forth in the Agreement, all documents forming the Contract (and all parts thereof) are intended to be correlative, complementary, and mutually explanatory. The Agreement shall be read as a whole.

3. Fraud and Corruption and Prohibited Practices

3.1 The Bank requires compliance with its policy in regard to fraud and corruption and prohibited practices as set forth in Attachment 1.

4. Interpretation

4.1 If the context so requires it, singular means plural and vice versa:

4.2 Incoterms

(a) Unless inconsistent with any provision of the Contract, the meaning of any trade term and the rights and obligations of parties thereunder shall be as prescribed by Incoterms.

(b) The terms CIP, FCA, CPT and other similar terms, when used, shall be governed by the rules prescribed in the current edition of Incoterms specified in the **SCC** and published by the International Chamber of Commerce in Paris, France.

4.3 Entire Agreement: The Contract constitutes the entire agreement between the Purchaser and the Supplier and supersedes all communications, negotiations and agreements (whether written or oral) of the parties with respect thereto made prior to the date of Contract.

4.4 Amendment: No amendment or other variation of the Contract shall be valid unless it is in writing, is dated, expressly refers to the Contract, and is signed by a duly authorized representative of each party thereto.

4.5 Nonwaiver

(a) Subject to GCC Sub-Clause 4.5(b) below, no relaxation, forbearance, delay, or indulgence by either party in enforcing any of the terms and conditions of the Contract or the granting of time by either party to the other shall prejudice, affect, or restrict the rights of that party under the Contract, neither shall any waiver by either party of any breach of Contract operate as waiver of any subsequent or continuing breach of Contract.

(b) Any waiver of a party’s rights, powers, or remedies under the Contract must be in writing, dated, and signed by an authorized representative of the party granting such waiver, and must specify the right and the extent to which it is being waived.

4.6 Severability: If any provision or condition of the Contract is prohibited or rendered invalid or unenforceable, such prohibition, invalidity or unenforceability shall not affect the validity or enforceability of any other provisions and conditions of the Contract.

5. Language

- 5.1 The Contract as well as all correspondence and documents relating to the Contract exchanged by the Supplier and the Purchaser, shall be written in the language specified in the SCC. Supporting documents and printed literature that are part of the Contract may be in another language provided they are accompanied by an accurate translation of the relevant passages in the language specified, in which case, for purposes of interpretation of the Contract, this translation shall govern.
- 5.2 The Supplier shall bear all costs of translation to the governing language and all risks of the accuracy of such translation, for documents provided by the Supplier.

6. Joint Venture, Consortium or Association

- 6.1 If the Supplier is a joint venture, consortium, or association, all of the parties shall be jointly and severally liable to the Purchaser for the fulfillment of the provisions of the Contract and shall designate one party to act as a leader with authority to bind the joint venture, consortium, or association. The composition or the constitution of the joint venture, consortium, or association shall not be altered without the prior consent of the Purchaser.

7. Eligibility

- 7.1 The Supplier and its Subcontractors shall have the nationality of a Bank's member country. A Supplier or Subcontractor shall be deemed to have the nationality of a country if it complies with the following requirements:
- (a) **An individual** is considered to be a national of a member country of the Bank if he or she meets either of the following requirements:
 - (i) is a citizen of a member country; or
 - (ii) has established his/her domicile in a member country as a "bona fide" resident and is legally entitled to work in the country of domicile.
 - (b) **A firm** is considered to have the nationality of a member country if it meets the two following requirements:
 - (i) is legally constituted or incorporated under the laws of a member country of the Bank; and
 - (ii) more than fifty percent (50%) of the firm's capital is owned by individuals or firms from member countries of the Bank.
- 7.2 All members of a JVCA and all subcontractors must meet the nationality criteria set forth above.
- 7.3 All the Goods and Related Services to be supplied under the Contract and financed by the Bank shall have their origin in any Bank's member country. Goods have their origin in a member country of the Bank if they have been mined, grown, harvested, or produced in a member country of the Bank. A good has been produced when through manufacture, processing or assembly another commercially recognized article results that differs substantially in its basic characteristics, function or purpose of utility from its parts or components. For a good consisting of several individual components that need to be interconnected (either by the supplier, the purchaser or

by a third party) to make the good operative and regardless of the complexity of the interconnection, the Bank considers that such good is eligible for financing if the assembly of the components took place in a member country, regardless of the origin of the components. When the good is a set of several individual goods that are normally packaged and sold commercially as a single unit, the good is considered to originate in the country where the set was packaged and shipped to the purchaser. For purpose of origin, goods labeled “made in the European Union” shall be eligible without the need to identify the corresponding specific country of the European Union. The origin of materials, parts or components of the goods or the nationality of the firm that produces, assembles, distributes or sells the goods, does not determine the origin of the goods.

8. Notices

- 8.1 Any notice given by one party to the other pursuant to the Contract shall be in writing to the address specified in the **SCC**. The term “in writing” means communicated in written form with proof of receipt.
- 8.2 A notice shall be effective when delivered or on the notice’s effective date, whichever is later.

9. Governing Law

- 9.1 The Contract shall be governed by and interpreted in accordance with the laws of the Purchaser’s Country, unless otherwise specified in the **SCC**.

10. Settlement of Disputes

- 10.1 The Purchaser and the Supplier shall make every effort to resolve amicably by direct informal negotiation any disagreement or dispute arising between them under or in connection with the Contract.
- 10.2 If, after twenty-eight (28) days, the parties have failed to resolve their dispute or difference by such mutual consultation, then either the Purchaser or the Supplier may give notice to the other party of its intention to commence arbitration, as hereinafter provided, as to the matter in dispute, and no arbitration in respect of this matter may be commenced unless such notice is given. Any dispute or difference in respect of which a notice of intention to commence arbitration has been given in accordance with this Clause shall be finally settled by arbitration. Arbitration may be commenced prior to or after delivery of the Goods under the Contract. Arbitration proceedings shall be conducted in accordance with the rules of procedure **specified in the SCC**.
- 10.3 Notwithstanding any reference to arbitration herein,
 - (a) the parties shall continue to perform their respective obligations under the Contract unless they otherwise agree; and
 - (b) the Purchaser shall pay the Supplier any monies due the Supplier.

11. Inspections and Audit by the Bank

- 11.1 The Supplier shall permit, and shall cause its Subcontractors and consultants to permit, the Bank and/or persons appointed by the Bank to inspect the Supplier’s

offices and all accounts and records relating to the performance of the Contract and the submission of the bid, and to have such accounts and records audited by auditors appointed by the Bank if requested by the Bank. The Supplier's and its Subcontractors and consultants' attention is drawn to Clause 3 Prohibited Practices, which provides, inter alia, that acts intended to materially impede the exercise of the Bank's inspection and audit rights provided for under this Sub-Clause 11.1 constitute a prohibited practice subject to contract termination (as well as to a determination of ineligibility pursuant to the Bank's prevailing sanctions procedures).

12. Scope of Supply

12.1 The Goods and Related Services to be supplied shall be as specified in the Schedule of Requirements.

13. Delivery of Documents

13.1 Subject to GCC Sub-Clause 33.1, the Delivery of the Goods and Completion of the Related Services shall be in accordance with the Delivery and Completion Schedule specified in the Schedule of Requirements. The details of shipping and other documents to be furnished by the Supplier are specified in the SCC.

14. Supplier's Responsibilities

14.1 The Supplier shall supply all the Goods and Related Services included in the Scope of Supply in accordance with GCC Clause 12, and the Delivery and Completion Schedule, as per GCC Clause 13.

15. Contract Price

15.1 Prices charged by the Supplier for the Goods supplied and the Related Services performed under the Contract shall not vary from the prices quoted by the Supplier in its bid, with the exception of any price adjustments authorized in the SCC.

16. Terms of Payment

16.1 The Contract Price, including any Advance Payments, if applicable, shall be paid as specified in the SCC.

16.2 The Supplier's request for payment shall be made to the Purchaser in writing, accompanied by invoices describing, as appropriate, the Goods delivered and Related Services performed, and by the documents submitted pursuant to GCC Clause 13 and upon fulfillment of all other obligations stipulated in the Contract.

16.3 Payments shall be made promptly by the Purchaser, but in no case later than sixty (60) days after submission of an invoice or request for payment by the Supplier, and after the Purchaser has accepted it.

16.4 The currencies in which payments shall be made to the Supplier under this Contract shall be those in which the bid price is expressed.

16.5 In the event that the Purchaser fails to pay the Supplier any payment by its due date or within the period set forth in the SCC, the Purchaser shall pay to the Supplier interest on the amount of such delayed payment at the rate shown in the SCC, for the

period of delay until payment has been made in full, whether before or after judgment or arbitrage award.

17. Taxes and Duties

- 17.1 For goods manufactured outside the Purchaser's Country, the Supplier shall be entirely responsible for all taxes, stamp duties, license fees, and other such levies imposed outside the Purchaser's Country.
- 17.2 For goods manufactured within the Purchaser's country, the Supplier shall be entirely responsible for all taxes, duties, license fees, etc., incurred until delivery of the contracted Goods to the Purchaser.
- 17.3 If any tax exemptions, reductions, allowances or privileges may be available to the Supplier in the Purchaser's Country, the Purchaser shall use its best efforts to enable the Supplier to benefit from any such tax savings to the maximum allowable extent.

18. Performance Security

- 18.1 If required as specified in the SCC, the Supplier shall, within twenty-eight (28) days of the notification of contract award, provide a performance security for the performance of the Contract in the amount specified in the SCC.
- 18.2 The proceeds of the Performance Security shall be payable to the Purchaser as compensation for any loss resulting from the Supplier's failure to complete its obligations under the Contract.
- 18.3 As specified in the SCC, the Performance Security, if required, shall be denominated in the currency(ies) of the Contract, or in a freely convertible currency acceptable to the Purchaser; and shall be in one of the format stipulated by the Purchaser in the SCC, or in another format acceptable to the Purchaser.
- 18.4 The Performance Security shall be discharged by the Purchaser and returned to the Supplier not later than twenty-eight (28) days following the date of Completion of the Supplier's performance obligations under the Contract, including any warranty obligations, unless specified otherwise in the SCC.

19. Copyright

- 19.1 The copyright in all drawings, documents, and other materials containing data and information furnished to the Purchaser by the Supplier herein shall remain vested in the Supplier, or, if they are furnished to the Purchaser directly or through the Supplier by any third party, including suppliers of materials, the copyright in such materials shall remain vested in such third party.

20. Confidential Information

- 20.1 The Purchaser and the Supplier shall keep confidential and shall not, without the written consent of the other party hereto, divulge to any third party any documents, data, or other information furnished directly or indirectly by the other party hereto in connection with the Contract, whether such information has been furnished prior to, during or following completion or termination of the Contract. Notwithstanding the above, the Supplier may furnish to its Subcontractor such documents, data, and other information it receives from the Purchaser to the extent required for the Subcontractor

to perform its work under the Contract, in which event the Supplier shall obtain from such Subcontractor an undertaking of confidentiality similar to that imposed on the Supplier under GCC Clause 20.

- 20.2 The Purchaser shall not use such documents, data, and other information received from the Supplier for any purposes unrelated to the contract. Similarly, the Supplier shall not use such documents, data, and other information received from the Purchaser for any purpose other than the performance of the Contract.
- 20.3 The obligation of a party under GCC Sub-Clauses 20.1 and 20.2 above, however, shall not apply to information that:
- (a) the Purchaser or Supplier need to share with the Bank or other institutions participating in the financing of the Contract;
 - (b) now or hereafter enters the public domain through no fault of that party;
 - (c) can be proven to have been possessed by that party at the time of disclosure and which was not previously obtained, directly or indirectly, from the other party; or
 - (d) otherwise lawfully becomes available to that party from a third party that has no obligation of confidentiality.
- 20.4 The above provisions of GCC Clause 20 shall not in any way modify any undertaking of confidentiality given by either of the parties hereto prior to the date of the Contract in respect of the Supply or any part thereof.
- 20.5 The provisions of GCC Clause 20 shall survive completion or termination, for whatever reason, of the Contract.

21. Subcontracting

- 21.1 The Supplier shall notify the Purchaser in writing of all subcontracts awarded under the Contract if not already specified in the bid. Such notification, in the original bid or later shall not relieve the Supplier from any of its obligations, duties, responsibilities, or liability under the Contract.
- 21.2 Subcontracts shall comply with the provisions of GCC Clauses 3 and 7.

22. Specifications and Standards

- 22.1 Technical Specifications and Drawings
- (a) The Goods and Related Services supplied under this Contract shall conform to the technical specifications and standards mentioned in Section VI, Schedule of Requirements and, when no applicable standard is mentioned, the standard shall be equivalent or superior to the official standards whose application is appropriate to the Goods' country of origin.
 - (b) The Supplier shall be entitled to disclaim responsibility for any design, data, drawing, specification or other document, or any modification thereof provided or designed by or on behalf of the Purchaser, by giving a notice of such disclaimer to the Purchaser.
 - (c) Wherever references are made in the Contract to codes and standards in accordance with which it shall be executed, the edition or the revised version of such codes and standards shall be those specified in the Schedule of Requirements. During Contract execution, any changes in any such codes and

standards shall be applied only after approval by the Purchaser and shall be treated in accordance with GCC Clause 33.

23. Packing and Documents

- 23.1 The Supplier shall provide such packing of the Goods as is required to prevent their damage or deterioration during transit to their final destination, as indicated in the Contract. During transit, the packing shall be sufficient to withstand, without limitation, rough handling and exposure to extreme temperatures, salt and precipitation, and open storage. Packing case size and weights shall take into consideration, where appropriate, the remoteness of the goods' final destination and the absence of heavy handling facilities at all points in transit.
- 23.2 The packing, marking, and documentation within and outside the packages shall comply strictly with such special requirements as shall be expressly provided for in the Contract, including additional requirements, if any, specified in the SCC, and in any other instructions ordered by the Purchaser.

24. Insurance

- 24.1 Unless otherwise specified in the SCC, the Goods supplied under the Contract shall be fully insured—in a freely convertible currency from an eligible country—against loss or damage incidental to manufacture or acquisition, transportation, storage, and delivery, in accordance with the applicable Incoterms or in the manner specified in the SCC.

25. Transportation

- 25.1 Unless otherwise specified in the SCC, responsibility for arranging transportation of the Goods shall be in accordance with the specified Incoterms.

26. Inspections and Tests

- 26.1 The Supplier shall at its own expense and at no cost to the Purchaser carry out all such tests and/or inspections of the Goods and Related Services as are specified in the SCC.
- 26.2 The inspections and tests may be conducted on the premises of the Supplier or its Subcontractor, at point of delivery, and/or at the Goods' final destination, or in another place in the Purchaser's Country as specified in the SCC. Subject to GCC Sub-Clause 26.3, if conducted on the premises of the Supplier or its Subcontractor, all reasonable facilities and assistance, including access to drawings and production data, shall be furnished to the inspectors at no charge to the Purchaser.
- 26.3 The Purchaser or its designated representative shall be entitled to attend the tests and/or inspections referred to in GCC Sub-Clause 26.2, provided that the Purchaser bear all of its own costs and expenses incurred in connection with such attendance including, but not limited to, all traveling and board and lodging expenses.
- 26.4 Whenever the Supplier is ready to carry out any such test and inspection, it shall give a reasonable advance notice, including the place and time, to the Purchaser. The Supplier shall obtain from any relevant third party or manufacturer any necessary

permission or consent to enable the Purchaser or its designated representative to attend the test and/or inspection.

- 26.5 The Purchaser may require the Supplier to carry out any test and/or inspection not required by the Contract but deemed necessary to verify that the characteristics and performance of the Goods comply with the technical specifications codes and standards under the Contract, provided that the Supplier's reasonable costs and expenses incurred in the carrying out of such test and/or inspection shall be added to the Contract Price. Further, if such test and/or inspection impedes the progress of manufacturing and/or the Supplier's performance of its other obligations under the Contract, due allowance will be made in respect of the Delivery Dates and Completion Dates and the other obligations so affected.
- 26.6 The Supplier shall provide the Purchaser with a report of the results of any such test and/or inspection.
- 26.7 The Purchaser may reject any Goods or any part thereof that fail to pass any test and/or inspection or do not conform to the specifications. The Supplier shall either rectify or replace such rejected Goods or parts thereof or make alterations necessary to meet the specifications at no cost to the Purchaser, and shall repeat the test and/or inspection, at no cost to the Purchaser, upon giving a notice pursuant to GCC Sub-Clause 26.4.
- 26.8 The Supplier agrees that neither the execution of a test and/or inspection of the Goods or any part thereof, nor the attendance by the Purchaser or its representative, nor the issue of any report pursuant to GCC Sub-Clause 26.6, shall release the Supplier from any warranties or other obligations under the Contract..

27. Liquidated Damages

- 27.1 Except as provided under GCC Clause 32, if the Supplier fails to deliver any or all of the Goods by the Date(s) of delivery or perform the Related Services within the period specified in the Contract, the Purchaser may without prejudice to all its other remedies under the Contract, deduct from the Contract Price, as liquidated damages, a sum equivalent to the percentage specified in the SCC of the delivered price of the delayed Goods or unperformed Services for each week or part thereof of delay until actual delivery or performance, up to a maximum deduction of the percentage specified in those SCC. Once the maximum is reached, the Purchaser may terminate the Contract pursuant to GCC Clause 35.

28. Warranty

- 28.1 The Supplier warrants that all the Goods are new, unused, and of the most recent or current models, and that they incorporate all recent improvements in design and materials, unless provided otherwise in the Contract.
- 28.2 Subject to GCC Sub-Clause 22.1(b), the Supplier further warrants that the Goods shall be free from defects arising from any act or omission of the Supplier or arising from design, materials, and workmanship, under normal use in the conditions prevailing in the country of final destination.
- 28.3 Unless otherwise specified in the SCC, the warranty shall remain valid for twelve (12) months after the Goods, or any portion thereof as the case may be, have been

delivered to and accepted at the final destination indicated in the SCC, or for eighteen (18) months after the date of shipment from the port or place of loading in the country of origin, whichever period concludes earlier.

- 28.4 The Purchaser shall give notice to the Supplier stating the nature of any such defects together with all available evidence thereof, promptly following the discovery thereof. The Purchaser shall afford all reasonable opportunity for the Supplier to inspect such defects.
- 28.5 Upon receipt of such notice, the Supplier shall, within the period specified in the SCC, expeditiously repair or replace the defective Goods or parts thereof, at no cost to the Purchaser.
- 28.6 If having been notified, the Supplier fails to remedy the defect within the period specified in the SCC, the Purchaser may proceed to take within a reasonable period such remedial action as may be necessary, at the Supplier's risk and expense and without prejudice to any other rights which the Purchaser may have against the Supplier under the Contract..

29. Patent Indemnity

- 29.1 The Supplier shall, subject to the Purchaser's compliance with GCC Sub-Clause 29.2, indemnify and hold harmless the Purchaser and its employees and officers from and against any and all suits, actions or administrative proceedings, claims, demands, losses, damages, costs, and expenses of any nature, including attorney's fees and expenses, which the Purchaser may suffer as a result of any infringement or alleged infringement of any patent, utility model, registered design, trademark, copyright, or other intellectual property right registered or otherwise existing at the date of the Contract by reason of:
 - (a) the installation of the Goods by the Supplier or the use of the Goods in the country where the Site is located; and
 - (b) the sale in any country of the products produced by the Goods.Such indemnity shall not cover any use of the Goods or any part thereof other than for the purpose indicated by or to be reasonably inferred from the Contract, neither any infringement resulting from the use of the Goods or any part thereof, or any products produced thereby in association or combination with any other equipment, plant, or materials not supplied by the Supplier, pursuant to the Contract.
- 29.2 If any proceedings are brought or any claim is made against the Purchaser arising out of the matters referred to in GCC Sub-Clause 29.1, the Purchaser shall promptly give the Supplier a notice thereof, and the Supplier may at its own expense and in the Purchaser's name conduct such proceedings or claim and any negotiations for the settlement of any such proceedings or claim.
- 29.3 If the Supplier fails to notify the Purchaser within twenty-eight (28) days after receipt of such notice that it intends to conduct any such proceedings or claim, then the Purchaser shall be free to conduct the same on its own behalf.
- 29.4 The Purchaser shall, at the Supplier's request, afford all available assistance to the Supplier in conducting such proceedings or claim, and shall be reimbursed by the Supplier for all reasonable expenses incurred in so doing.

29.5 The Purchaser shall indemnify and hold harmless the Supplier and its employees, officers, and Subcontractors from and against any and all suits, actions or administrative proceedings, claims, demands, losses, damages, costs, and expenses of any nature, including attorney's fees and expenses, which the Supplier may suffer as a result of any infringement or alleged infringement of any patent, utility model, registered design, trademark, copyright, or other intellectual property right registered or otherwise existing at the date of the Contract arising out of or in connection with any design, data, drawing, specification, or other documents or materials provided or designed by or on behalf of the Purchaser.

30. Limitation of Liability

- 30.1 Except in cases of criminal negligence or willful misconduct,
- (a) the Supplier shall not be liable to the Purchaser, whether in contract, tort, or otherwise, for any indirect or consequential loss or damage, loss of use, loss of production, or loss of profits or interest costs, provided that this exclusion shall not apply to any obligation of the Supplier to pay liquidated damages to the Purchaser and
 - (b) the aggregate liability of the Supplier to the Purchaser, whether under the Contract, in tort or otherwise, shall not exceed the total Contract Price, provided that this limitation shall not apply to the cost of repairing or replacing defective equipment, or to any obligation of the supplier to indemnify the purchaser with respect to patent infringement.

31. Changes in Laws and Regulations

31.1 Unless otherwise specified in the Contract, if after the date of 28 days prior to date of Bid submission, any law, regulation, ordinance, order or bylaw having the force of law is enacted, promulgated, abrogated, or changed in the place of the Purchaser's country where the Site is located (which shall be deemed to include any change in interpretation or application by the competent authorities) that subsequently affects the Delivery Date and/or the Contract Price, then such Delivery Date and/or Contract Price shall be correspondingly increased or decreased, to the extent that the Supplier has thereby been affected in the performance of any of its obligations under the Contract. Notwithstanding the foregoing, such additional or reduced cost shall not be separately paid or credited if the same has already been accounted for in the price adjustment provisions where applicable, in accordance with GCC Clause 15.

32. Force Majeure

- 32.1 The Supplier shall not be liable for forfeiture of its Performance Security, liquidated damages, or termination for default if and to the extent that its delay in performance or other failure to perform its obligations under the Contract is the result of an event of Force Majeure.
- 32.2 For purposes of this Clause, "Force Majeure" means an event or situation beyond the control of the Supplier that is not foreseeable, is unavoidable, and its origin is not due to negligence or lack of care on the part of the Supplier. Such events may include,

but not be limited to, acts of the Purchaser in its sovereign capacity, wars or revolutions, fires, floods, epidemics, quarantine restrictions, and freight embargoes.

- 32.3 If a Force Majeure situation arises, the Supplier shall promptly notify the Purchaser in writing of such condition and the cause thereof. Unless otherwise directed by the Purchaser in writing, the Supplier shall continue to perform its obligations under the Contract as far as is reasonably practical, and shall seek all reasonable alternative means for performance not prevented by the Force Majeure event.

33. Change Orders and Contract Amendments

- 33.1 The Purchaser may at any time order the Supplier through notice in accordance GCC Clause 8, to make changes within the general scope of the Contract in any one or more of the following:
- (a) drawings, designs, or specifications, where Goods to be furnished under the Contract are to be specifically manufactured for the Purchaser;
 - (b) the method of shipment or packing;
 - (c) the place of delivery; and
 - (d) the Related Services to be provided by the Supplier.
- 33.2 If any such change causes an increase or decrease in the cost of, or the time required for, the Supplier's performance of any provisions under the Contract, an equitable adjustment shall be made in the Contract Price or in the Delivery/Completion Schedule, or both, and the Contract shall accordingly be amended. Any claims by the Supplier for adjustment under this Clause must be asserted within twenty-eight (28) days from the date of the Supplier's receipt of the Purchaser's change order.
- 33.3 Prices to be charged by the Supplier for any Related Services that might be needed but which were not included in the Contract shall be agreed upon in advance by the parties and shall not exceed the prevailing rates charged to other parties by the Supplier for similar services.
- 33.4 Subject to the above, no variation in or modification of the terms of the Contract shall be made except by written amendment signed by the parties.

34. Extension of Time

- 34.1 If at any time during performance of the Contract, the Supplier or its subcontractors should encounter conditions impeding timely delivery of the Goods or completion of Related Services pursuant to GCC Clause 13, the Supplier shall promptly notify the Purchaser in writing of the delay, its likely duration, and its cause. As soon as practicable after receipt of the Supplier's notice, the Purchaser shall evaluate the situation and may at its discretion extend the Supplier's time for performance, in which case the extension shall be ratified by the parties by amendment of the Contract.
- 34.2 Except in case of Force Majeure, as provided under GCC Clause 32, a delay by the Supplier in the performance of its Delivery and Completion obligations shall render the Supplier liable to the imposition of liquidated damages pursuant to GCC Clause 26, unless an extension of time is agreed upon, pursuant to GCC Sub-Clause 34.1.

35. Termination

35.1 Termination for Default

- (a) The Purchaser, without prejudice to any other remedy for breach of Contract, by written notice of default sent to the Supplier, may terminate the Contract in whole or in part:
 - (i) if the Supplier fails to deliver any or all of the Goods within the period specified in the Contract, or within any extension thereof granted by the Purchaser pursuant to GCC Clause 34;
 - (ii) if the Supplier fails to perform any other obligation under the Contract; or
 - (iii) if the Supplier, in the judgment of the Purchaser has engaged in prohibited practices, as defined in GCC Clause 3, in competing for or in executing the Contract.
- (b) In the event the Purchaser terminates the Contract in whole or in part, pursuant to GCC Clause 35.1(a), the Purchaser may procure, upon such terms and in such manner as it deems appropriate, Goods or Related Services similar to those undelivered or not performed, and the Supplier shall be liable to the Purchaser for any additional costs for such similar Goods or Related Services. However, the Supplier shall continue performance of the Contract to the extent not terminated.

35.2 Termination for Insolvency

- (a) The Purchaser may at any time terminate the Contract by giving notice to the Supplier if the Supplier becomes bankrupt or otherwise insolvent. In such event, termination will be without compensation to the Supplier, provided that such termination will not prejudice or affect any right of action or remedy that has accrued or will accrue thereafter to the Purchaser.

35.3 Termination for Convenience

- (a) The Purchaser, by notice sent to the Supplier, may terminate the Contract, in whole or in part, at any time for its convenience. The notice of termination shall specify that termination is for the Purchaser's convenience, the extent to which performance of the Supplier under the Contract is terminated, and the date upon which such termination becomes effective.
- (b) The Goods that are complete and ready for shipment within twenty-eight (28) days after the Supplier's receipt of notice of termination shall be accepted by the Purchaser at the Contract terms and prices. For the remaining Goods, the Purchaser may elect:
 - (i) to have any portion completed and delivered at the Contract terms and prices; and/or
 - (ii) to cancel the remainder and pay to the Supplier an agreed amount for partially completed Goods and Related Services and for materials and parts previously procured by the Supplier.

36. Assignment

- 36.1 Neither the Purchaser nor the Supplier shall assign, in whole or in part, their obligations under this Contract, except with prior written consent of the other party.

37. Export Restriction

- 37.1 Notwithstanding any obligation under the Contract to complete all export formalities, any export restrictions attributable to the Purchaser, to the country of the Purchaser, or to the use of the products/goods, systems or services to be supplied, which arise from trade regulations from a country supplying those products/goods, systems or services, and which substantially impede the Supplier from meeting its obligations under the Contract, shall release the Supplier from the obligation to provide deliveries or services, always provided, however, that the Supplier can demonstrate to the satisfaction of the Purchaser and of the Bank that it has completed all formalities in a timely manner, including applying for permits, authorizations and licenses necessary for the export of the products/goods, systems or services under the terms of the Contract. Termination of the Contract on this basis shall be for the Purchaser's convenience pursuant to Sub-Clause 35.3.

RE TENDERED

Section IX. Special Conditions of Contract

The following Special Conditions of Contract (SCC) shall supplement and / or amend the General Conditions of Contract (GCC). Whenever there is a conflict, the provisions herein shall prevail over those in the GCC.

[The Purchaser shall select insert the appropriate wording using the samples below or other acceptable wording, and delete the text in italics]

GCC 1.1(j)	The Purchaser's country is: <i>[insert name of the Purchaser's Country]</i>
GCC 1.1(k)	The Purchaser is: <i>[Insert complete legal name of the Purchaser]</i>
GCC 1.1 (q)	The Project Site(s)/Final Destination(s) is/are: <i>[Insert name(s) and detailed information on the location(s) of the site(s)]</i>
GCC 4.2 (a)	The meaning of the trade terms shall be as prescribed by Incoterms. If the meaning of any trade term and the rights and obligations of the parties thereunder shall not be as prescribed by Incoterms, they shall be as prescribed by: <i>[exceptional; refer to other internationally accepted trade terms]</i>
GCC 4.2 (b)	The version edition of Incoterms shall be <i>[insert date of current edition]</i>
GCC 5.1	The language shall be: <i>[insert the name of the language]</i>
GCC 8.1	For <u>notices</u> , the Purchaser's address shall be: Attention: <i>[insert full name of person, if applicable]</i> Street Address: <i>[insert street address and number]</i> Floor/ Room number: <i>[insert floor and room number, if applicable]</i> City: <i>[insert name of city or town]</i> ZIP Code: <i>[insert postal ZIP code, if applicable]</i> Country: <i>[insert name of country]</i> Telephone: <i>[include telephone number, including country and city codes]</i> Facsimile number: <i>[insert facsimile number, including country and city codes]</i> Electronic mail address: <i>[insert e-mail address, if applicable]</i>
GCC 9.1	The governing law shall be the law of: <i>[insert name of the country or state]</i>
GCC 10.2	The rules of procedure for arbitration proceedings pursuant to GCC Clause 10.2 shall be as follows: <i>[The bidding documents should contain one clause to be retained in the event of a Contract with a foreign Supplier and one clause to be retained in the event of a Contract with a Supplier who is a national of the Purchaser's country. At the time of finalizing the Contract, the respective applicable clause should be retained in the Contract. The following explanatory</i>

note should therefore be inserted as a header to GCC 10.2 in the bidding document.

“Clause 10.2 (a) shall be retained in the case of a Contract with a foreign Supplier and clause 10.2 (b) shall be retained in the case of a Contract with a national of the Purchaser’s country.”]

(a) Contract with foreign Supplier:

[For contracts entered into with foreign suppliers, International commercial arbitration may have practical advantages over other dispute settlement methods. The Inter-American Development Bank should not be named as arbitrator, nor should it be asked to name an arbitrator. Among the rules to govern the arbitration proceedings, the Purchaser may wish to consider the United Nations Commission on International Trade Law (UNCITRAL) Arbitration Rules of 1976, the Rules of Conciliation and Arbitration of the International Chamber of Commerce (ICC), the Rules of the London Court of International Arbitration or the Rules of Arbitration Institute of the Stockholm Chamber of Commerce.]

If the Purchaser chooses the UNCITRAL Arbitration Rules, the following sample clause should be inserted:

GCC 10.2 (a)—Any dispute, controversy or claim arising out of or relating to this Contract, or breach, termination or invalidity thereof, shall be settled by arbitration in accordance with the UNCITRAL Arbitration Rules as at present in force.

If the Purchaser chooses the Rules of ICC, the following sample clause should be inserted:

GCC 10.2 (a)—All disputes arising in connection with the present Contract shall be finally settled under the Rules of Conciliation and Arbitration of the International Chamber of Commerce by one or more arbitrators appointed in accordance with said Rules.

If the Purchaser chooses the Rules of Arbitration Institute of Stockholm Chamber of Commerce, the following sample clause should be inserted:

GCC 10.2 (a)—Any dispute, controversy or claim arising out of or in connection with this Contract, or the breach termination or invalidity thereof, shall be settled by arbitration in accordance with the Rules of the Arbitration Institute of the Stockholm Chamber of Commerce.

If the Purchaser chooses the Rules of the London Court of International Arbitration, the following clause should be inserted:

GCC 10.2 (a)—Any dispute arising out of or in connection with this Contract, including any question regarding its existence,

	<p>validity or termination shall be referred to and finally resolved by arbitration under the Rules of the London Court of International Arbitration, which rules are deemed to be incorporated by reference to this clause.</p> <p><i>(b) Contracts with Supplier national of the Purchaser's country:</i></p> <p>In the case of a dispute between the Purchaser and a Supplier who is a national of the Purchaser's country, the dispute shall be referred to adjudication or arbitration in accordance with the laws of the Purchaser's country.</p>
GCC 13.1	<p>Details of Shipping and other Documents to be furnished by the Supplier are <i>[insert the required documents, such as a negotiable bill of lading, a non-negotiable sea way bill, an airway bill, a railway consignment note, a road consignment note, insurance certificate, Manufacturer's or Supplier's warranty certificate, inspection certificate issued by nominated inspection agency, Supplier's factory shipping details etc]</i>.</p> <p>The above documents shall be received by the Purchaser before arrival of the Goods and, if not received, the Supplier will be responsible for any consequent expenses.</p>
GCC 15.1	<p>The prices charged for the Goods supplied and the related Services performed <i>[insert "shall" or "shall not," as appropriate]</i> be adjustable. If prices are adjustable, the following method shall be used to calculate the price adjustment <i>[see attachment to these SCC for a sample Price Adjustment Formula]</i></p>
GCC 16.1	<p><i>Sample provision</i></p> <p>GCC 16.1—The method and conditions of payment to be made to the Supplier under this Contract shall be as follows:</p> <p>Payment for Goods supplied from abroad:</p> <p>Payment of foreign currency portion shall be made in (</p> <hr/> <p>) <i>[currency of the Contract Price]</i> in the following manner:</p> <p>(i) Advance Payment: Ten (10) percent of the Contract Price shall be paid within thirty (30) days of signing of the Contract, and upon submission of claim and a bank guarantee for equivalent amount valid until the Goods are delivered and in the form provided in the bidding documents or another form acceptable to the Purchaser.</p> <p>(ii) On Shipment: Eighty (80) percent of the Contract Price of the Goods shipped shall be paid through irrevocable confirmed letter of credit opened in favor of the Supplier in a bank in its country, upon submission of documents specified in GCC Clause 12.</p> <p>(iii) On Acceptance: Ten (10) percent of the Contract Price of Goods received shall be paid within thirty (30) days of receipt</p>

	<p>of the Goods upon submission of claim supported by the acceptance certificate issued by the Purchaser.</p> <p>Payment of local currency portion shall be made in <i>[currency]</i> within thirty (30) days of presentation of claim supported by a certificate from the Purchaser declaring that the Goods have been delivered and that all other contracted Services have been performed.</p> <p>Payment for Goods and Services supplied from within the Purchaser's country:</p> <p>Payment for Goods and Services supplied from within the Purchaser's country shall be made in <i>[currency]</i>, as follows:</p> <ul style="list-style-type: none"> (i) Advance Payment: Ten (10) percent of the Contract Price shall be paid within thirty (30) days of signing of the Contract against a simple receipt and a bank guarantee for the equivalent amount and in the form provided in the bidding documents or another form acceptable to the Purchaser. (ii) On Delivery: Eighty (80) percent of the Contract Price shall be paid on receipt of the Goods and upon submission of the documents specified in GCC Clause 13. (iii) On Acceptance: The remaining ten (10) percent of the Contract Price shall be paid to the Supplier within thirty (30) days after the date of the acceptance certificate for the respective delivery issued by the Purchaser.
GCC 16.5	<p>The payment-delay period after which the Purchaser shall pay interest to the supplier shall be <i>[insert number]</i> days.</p> <p>The interest rate that shall be applied is <i>[insert number]</i> %</p>
GCC 18.1	<p>A Performance Security <i>[insert "shall" or "shall not" be required]</i></p> <p><i>[If a Performance Security is required, insert "the amount of the Performance Security shall be: [insert amount]</i></p> <p><i>[The amount of the Performance Security is usually expressed as a percentage of the Contract Price. The percentage varies according to the Purchaser's perceived risk and impact of non-performance by the Supplier. A 10% percentage is used under normal circumstances]</i></p>
GCC 18.3	<p>If required, the Performance Security shall be in the form of : <i>[insert "a Bank Guarantee" or "a Performance Bond"]</i></p> <p>If required, the Performance security shall be denominated in <i>[insert "a freely convertible currency acceptable to the Purchaser" or " the currencies of payment of the Contract, in accordance with their portions of the Contract Price"]</i></p>
GCC 18.4	<p>Discharge of the Performance Security shall take place: <i>[insert date if different from the one indicated in sub clause GCC 18.4]</i></p>

GCC 23.2	The packing, marking and documentation within and outside the packages shall be: <i>[insert in detail the type of packing required, the markings in the packing and all documentation required]</i>
GCC 24.1	The insurance coverage shall be as specified in the Incoterms. If not in accordance with Incoterms, insurance shall be as follows: <i>[insert specific insurance provisions agreed upon, including coverage, currency an amount]</i>
GCC 25.1	Responsibility for transportation of the Goods shall be as specified in the Incoterms. If not in accordance with Incoterms, responsibility for transportations shall be as follows: <i>[insert “The Supplier is required under the Contract to transport the Goods to a specified place of final destination within the Purchaser’s country, defined as the Project Site, transport to such place of destination in the Purchaser’s country, including insurance and storage, as shall be specified in the Contract, shall be arranged by the Supplier, and related costs shall be included in the Contract Price”; or any other agreed upon trade terms (specify the respective responsibilities of the Purchaser and the Supplier)]</i>
GCC 26.1	The inspections and tests shall be: <i>[insert nature, frequency, procedures for carrying out the inspections and tests]</i>
GCC 26.2	The Inspections and tests shall be conducted at: <i>[insert name(s) of location(s)]</i>
GCC 27.1	The liquidated damage shall be: <i>[insert number]</i> % per week
GCC 27.1	The maximum amount of liquidated damages shall be: <i>[insert number]</i> %
GCC 28.3	The period of validity of the Warranty shall be: <i>[insert number]</i> days For purposes of the Warranty, the place(s) of final destination(s) shall be: <i>[insert name(s) of location(s)]</i>
GCC 28.5	The period for repair or replacement shall be: <i>[insert number(s)]</i> days.

Attachment 1: Price Adjustment Formula

If in accordance with GCC 15.2, prices shall be adjustable, the following method shall be used to calculate the price adjustment:

- 15.2 Prices payable to the Supplier, as stated in the Contract, shall be subject to adjustment during performance of the Contract to reflect changes in the cost of labor and material components in accordance with the formula:

$$P_1 = P_0 \left[a + \frac{bL_1}{L_0} + \frac{cM_1}{M_0} \right] - P_0$$

$$a+b+c = 1$$

in which:

- P_1 = adjustment amount payable to the Supplier.
 P_0 = Contract Price (base price).
 a = fixed element representing profits and overheads included in the Contract Price and generally in the range of five (5) to fifteen (15) percent.
 b = estimated percentage of labor component in the Contract Price.
 c = estimated percentage of material component in the Contract Price.
 L_0, L_1 = labor indices applicable to the appropriate industry in the country of origin on the base date and date for adjustment, respectively.
 M_0, M_1 = material indices for the major raw material on the base date and date for adjustment, respectively, in the country of origin.

The coefficients a , b , and c as specified by the Purchaser are as follows:

$a =$ *[insert value of coefficient]*

$b =$ *[insert value of coefficient]*

$c =$ *[insert value of coefficient]*

The Bidder shall indicate the source of the indices and the base date indices in its bid.

Base date = thirty (30) days prior to the deadline for submission of the bids.

Date of adjustment = *[insert number of weeks]* weeks prior to date of shipment (representing the mid-point of the period of manufacture).

The above price adjustment formula shall be invoked by either party subject to the following further conditions:

- (a) No price adjustment shall be allowed beyond the original delivery dates unless specifically stated in the extension letter. As a rule, no price adjustment shall be allowed for periods of delay for which the Supplier is entirely responsible. The Purchaser will, however, be entitled to any decrease in the prices of the Goods and Services subject to adjustment.
- (b) If the currency in which the Contract Price P_0 is expressed is different from the currency of origin of the labor and material indices, a correction factor will be applied to avoid incorrect adjustments of the Contract Price. The correction factor shall correspond to the ratio of exchange rates between the two currencies on the base date and the date for adjustment as defined above.

- (c) No price adjustment shall be payable on the portion of the Contract Price paid to the Supplier as advance payment.

RE TENDERED

Attachment 2: Fraud and Corruption and Prohibited Practices

Fraud and Corruption

[Clause applicable to loan agreements signed under policy GN-2349-7]

1. The Bank requires that all borrowers (including grant beneficiaries), executing agencies and contracting agencies as well as all firms, entities and individuals bidding for or participating in a Bank-financed project including, inter alia, bidders, suppliers, contractors, consultants and concessionaries (including their respective officers, employees and agents) adhere to the highest ethical standards, and report to the Bank all suspected acts of fraud or corruption of which they have knowledge or become aware both, during the Bidding Process and throughout negotiation or execution of a contract. Fraud and corruption are prohibited. Fraud and corruption include acts of: (a) corrupt practice, (b) fraudulent practice, (c) coercive practice and (d) collusive practice. The definitions set forth below involve the most common types of fraud and corruption, but are not exhaustive. For this reason, the Bank shall also take action in the event of any similar deed or complaint involving alleged acts of fraud and corruption, even when these are not specified in the following list. The Bank shall in all cases proceed with the established procedure referred to in paragraph 1 (c).
 - (a) The Bank defines, for the purposes of this provision, the terms set forth below:
 - (i) A corrupt practice is the offering, giving, receiving, or soliciting, directly or indirectly, anything of value to influence improperly the actions of another party;
 - (ii) A fraudulent practice is any act or omission, including a misrepresentation, that knowingly or recklessly misleads, or attempts to mislead, a party to obtain a financial or other benefit or to avoid an obligation;
 - (iii) A coercive practice is impairing or harming, or threatening to impair or harm, directly or indirectly, any party or the property of the party to improperly influence the actions of a party; and
 - (iv) A collusive practice is an arrangement between two or more parties designed to achieve an improper purpose, including influencing improperly the actions of another party.
 - (b) If the Bank, in accordance with its administrative procedures, demonstrates that any firm, entity or individual bidding for or participating in a Bank-financed project including, inter alia, borrowers, bidders, suppliers, contractors, subcontractors, consultant and concessionaires, executing agencies or contracting agencies (including their respective officers, employees and agents) has engaged in an act of fraud or corruption, the Bank may:
 - (i) decide not to finance any proposal to award a contract or a contract awarded for works, goods, and related services financed by the Bank;
 - (ii) suspend disbursement of the operation if it is determined at any stage that evidence is sufficient to support a finding that an employee, agent or representative of the Borrower, Executing Agency or Contracting Agency has engaged in an act of fraud or corruption;
 - (iii) cancel and/or accelerate repayment of, the portion of a loan or grant earmarked for a contract, when there is evidence that the representative of the Borrower, or Beneficiary of a grant, has not taken the adequate remedial measures within a time period which the Bank considers reasonable, and in accordance with the due process guarantees of the borrowing country's legislation;

- (iv) issue a reprimand in the form of a formal letter of censure of the firm, entity or individual's behavior;
 - (v) issue a declaration that an individual, entity or firm is ineligible, either permanently or for a stated period of time, to be awarded or participate in contracts under Bank-financed projects except under such conditions as the Bank deems to be appropriate;
 - (vi) refer the matter to appropriate law enforcement authorities; and/or
 - (vii) impose other sanctions that it deems to be appropriate under the circumstances, including the imposition of fines representing reimbursement to the Bank for costs associated with investigations and proceedings. Such other sanctions may be imposed in addition to or in lieu of other sanctions.
- (c) The Bank has established administrative procedures for cases of allegations of fraud and corruption within the procurement process or the execution of a contract financed by the Bank which are available at the Bank's website (www.iadb.org), as updated from time to time. To that effect any complaint shall be submitted to the Bank's Office of Institutional Integrity (OII) for the appropriated investigation. Allegations may be presented confidentially or anonymously.
- (d) Payments are expressly conditional upon the claimant's participation in the procurement process conformed with all applicable Bank policies on Fraud and Corruption described in this paragraph 1.
- (e) The imposition of any action to be taken by the Bank pursuant to the provisions referred to paragraph (b) of this Clause may be public or private, in accordance with the policies of the Bank.
2. The Bank will have the right to require that, in contracts financed with a Bank loan, a provision be included requiring Bidders, suppliers, contractors, subcontractors, consultants and concessionaires to permit the Bank to inspect their accounts and records and any other documents relating to the submission of bids and contract performance and to have them audited by auditors appointed by the Bank. The Bank will have the right to require that, in contracts financed with a Bank loan, a provision be included requiring Bidders, suppliers, contractors, subcontractors, consultants and concessionaires to: (i) maintain all documents and records related to the Bank-financed project for three (3) years after completion of the work contemplated in the relevant Contract; and (ii) deliver any document necessary for the investigation of allegations of fraud or corruption and make available to the Bank the employees or agents of the Bidders, suppliers, contractors, subcontractors, consultants or concessionaires with knowledge of the Bank-financed project to respond to questions from Bank personnel or any properly designated investigator, agent, auditor or consultant relating to the review or audit of the documents. If the Bidder, supplier, contractor, subcontractor, consultant or concessionaire fails to comply with the Bank's request, or otherwise obstruct the Bank's review of the matter, the Bank, in its sole discretion, may take appropriate action against the Bidder, supplier, contractor, subcontractor, consultant or concessionaire.
3. Bidders shall represent and warrant:
- (a) that they have read and understood the Bank's prohibition against fraud and corruption and agrees to abide by the applicable rules;
 - (b) that they have not engaged in any violation of policies on fraud and corruption described herein;

- (c) that they have not misrepresented or concealed any material facts during the procurement or contract negotiation processes or performance of the contract;
 - (d) that neither they nor any of their directors, officers or principal shareholders have been declared ineligible to be awarded Bank-financed contracts or have been convicted of a crime involving fraud or corruption;
 - (e) that none of their directors, officers or principal shareholders has been a director, officer or principal shareholder of any other company or entity that has been declared ineligible to be awarded a Bank-financed contract or has been convicted of a crime involving fraud or corruption;
 - (f) that all commissions, agents' fees, facilitating payments or revenue-sharing agreements related to the Bank-financed contract or consulting agreement have been disclosed;
 - (g) that they acknowledge that the breach of any of these warranties constitute a basis for the imposition of any or a combination of the measures described in paragraph 1 (b).
-
-

Prohibited Practices

[Clause applicable to loan agreements signed under policy GN-2340-9]

1. The Bank requires that all Borrowers (including grant beneficiaries), Executing Agencies and Contracting Agencies as well as all firms, entities and individuals bidding for or participating in a Bank-financed activity including, inter alia, applicants, bidders, suppliers, contractors, consultants, personnel, sub-contractors, sub-consultants, service providers and concessionaires (including their respective officers, employees and agents irrespective of whether the agency is express or implied), adhere to the highest ethical standards, and report to the Bank⁴ all suspected acts of Prohibited Practices of which they have knowledge or become aware both, during the bidding process and throughout negotiation or execution of a contract. Prohibited Practices include acts of: (i) corrupt practices, (ii) fraudulent practices, (iii) coercive practices, and (iv) collusive practices and (v) obstructive practices. The Bank has established mechanisms to report allegations of Prohibited Practices. Any allegation shall be submitted to the Bank's Office of Institutional Integrity (OII) for the appropriate investigation. The Bank has also adopted sanctions procedures to adjudicate cases. The Bank has also entered into agreements with other International Financial Institutions (IFIs) to mutually recognize sanctions imposed by their respective sanctioning bodies.
 - (a) The Bank defines, for the purposes of this provision, the terms set forth below:
 - (i) A "corrupt practice" which is the offering, giving, receiving, or soliciting, directly or indirectly, anything of value to influence improperly the actions of another party;
 - (ii) A "fraudulent practice" is any act or omission, including a misrepresentation, that knowingly or recklessly misleads, or attempts to mislead, a party to obtain a financial or other benefit or to avoid an obligation;

⁴ Information on how to present allegations of Prohibited Practices, the applicable rules regarding the investigation and sanctions process, and the agreement regulating the mutual recognition of sanctions among the IFIs are available on the Bank's website (www.iadb.org/integrity).

- (iii) A “coercive practice” is impairing or harming, or threatening to impair or harm, directly or indirectly, any party or the property of the party to influence improperly the actions of a party;
- (iv) A “collusive practice” is an arrangement between two or more parties designed to achieve an improper purpose, including influencing improperly the actions of another party; and
- (v) An “obstructive practice” which is:
 - a. deliberately destroying, falsifying, altering or concealing evidence material to the investigation or making false statements to investigators in order to materially impede a Bank Group investigation into allegations of a corrupt, fraudulent, coercive or collusive practice; and/or threatening, harassing or intimidating any party to prevent it from disclosing its knowledge of matters relevant to the investigation or from pursuing the investigation; or
 - b. acts intended to materially impede the exercise of the Bank’s inspection and audit rights provided for under paragraph 1 (f) below.
- (b) If, in accordance with the Sanctions Procedures of the Bank, it is determined that at any stage of the procurement or implementation of a contract any firm, entity or individual bidding for or participating in a Bank-financed activity including, inter alia, applicants, bidders, suppliers, contractors, consultants, personnel, sub-contractors, sub-consultants, goods or service providers, concessionaires, Borrowers (including grant Beneficiaries) Executing Agencies or Contracting Agencies (including their respective officers, employees and agents irrespective of whether the agency is express or implied) engaged in a Prohibited Practice the Bank may:
 - (i) not finance any proposal to award a contract for works, goods or services, and consulting services;
 - (ii) suspend disbursement of the operation if it is determined at any stage that an employee, agent or representative of the Borrower, Executing Agency or Contracting Agency has engaged in a Prohibited Practice;
 - (iii) declare Misprocurement and cancel, and/or accelerate repayment of the portion of a loan or grant earmarked for a contract, when there is evidence that the representative of the Borrower, or Beneficiary of a grant, has not taken the adequate remedial measures (including, inter alia, providing adequate notice to the Bank upon learning of the Prohibited Practice) within a time period which the Bank considers reasonable;
 - (iv) issue the firm, entity or individual a reprimand in the form of a formal letter of censure for its behavior;
 - (v) declare that a firm, entity, or individual is ineligible, either permanently or for a stated period of time, to (i) be awarded a contract or participate in activities financed by the Bank; and (ii) be nominated⁵ sub-consultant, sub-contractor, supplier or service provider of an otherwise eligible firm being awarded a Bank-financed contract;
 - (vi) refer the matter to appropriate law enforcement authorities; and/or

⁵ A nominated sub-consultant, sub-contractor, supplier, or service provider (different names are used depending on the particular bidding document) is one which has either been: (i) included by the bidder in its pre-qualification application or bid because it brings specific and critical experience and know-how that allow the bidder to meet the qualification requirements for the particular bid; or (ii) appointed by the Borrower.

- (vii) impose other sanctions that it deems to be appropriate under the circumstances, including the imposition of fines representing reimbursement of the Bank for costs associated with investigations and proceedings. Such other sanctions may be imposed in addition to or in lieu of the sanctions referred above.
- (c) The provisions of sub-paragraphs 1 (b) (i) and (ii) shall also be applicable when such parties have been temporarily suspended from eligibility to be awarded additional contracts pending a final outcome of a sanction proceeding, or otherwise.
- (d) The imposition of any action to be taken by the Bank pursuant to the provisions referred to above will be public.
- (e) In addition, any firm, entity or individual bidding for or participating in a Bank-financed activity including, inter alia, applicants, bidders, suppliers, contractors, consultants, personnel, sub-contractors, sub-consultants, service providers, concessionaires, Borrowers (including grant Beneficiaries), Executing Agencies or Contracting Agencies (including their respective officers, employees, and agents, irrespective of whether the agency is express or implied) may be subject to sanctions pursuant to agreements that the Bank may have with other International Financial Institutions (IFIs) regarding the mutual enforcement of debarment decisions. For purposes of this paragraph the term “sanction” shall mean any debarment, conditions on future contracting or any publicly-disclosed action taken in response to a violation of an IFI’s applicable framework for addressing allegations of Prohibited Practices.
- (f) The Bank requires that all applicants bidders, suppliers, and their agents, contractors, consultants, personnel, sub-contractors, service providers and concessionaires permit the Bank to inspect any and all accounts, records and other documents relating to the submission of bids and contract performance as well as to have them audited by auditors appointed by the Bank. Applicants, bidders, suppliers, and their agents, contractors, consultants, sub-contractors, sub-consultants, service providers and concessionaires shall fully assist the Bank with its investigation. The Bank also requires that all applicants, bidders, suppliers, and their agents, contractors, consultants, personnel, sub-contractors, sub-consultants, service providers and concessionaires: (i) maintain all documents and records related to the Bank-financed activities for seven (7) years after completion of the work contemplated in the relevant contract; and (ii) deliver any document necessary for the investigation of allegations of Prohibited Practices and make available employees or agents of the applicants, bidders, suppliers and their agents, contractors, consultants, personnel, sub-contractors, sub-consultants, service providers or concessionaires with knowledge of the Bank-financed activities to respond to questions from Bank personnel or any properly designated investigator, agent, auditor or consultant relating to the investigation. If the applicant, bidder, supplier and its agent, contractor, consultant, personnel, sub-contractor, sub-consultant, service provider or concessionaire fails to cooperate and/or comply with the Bank’s request, or otherwise obstructs the investigation, the Bank, in its sole discretion, may take appropriate action against the applicant bidder, supplier and its agent, contractor, consultant, personnel, sub-contractor, service provider or concessionaire.
- (g) If the Borrowers procures goods or services, works or consulting services directly from a specialized agency, all provisions under Section VI regarding sanctions and Prohibited Practices shall apply in their entirety to applicants, bidders, suppliers and their agents, contractors, consultants, personnel, sub-contractors, sub-consultants, service providers,

and concessionaires, (including their respective officers, employees, and agents, irrespective of whether the agency is express or implied), or to any other entities that signed contracts with such specialized agency to supply such goods, works, or non-consulting services in connection with the Bank-financed activities. The Bank will retain the right to require the Borrower to invoke remedies such as contract suspension or termination. Specialized agencies shall consult the Bank's list of firms and individuals suspended or debarred. In the event a specialized agency signs a contract or purchase order with a firm or an individual suspended or debarred by the Bank, the Bank will not finance the related expenditures and will apply other remedies as appropriate.

2. The Supplier represents and warrants:

- (a) that they have read and understood the Bank's definition of Prohibited Practices and the sanctions imposed in case Prohibited Practices take place and that they will comply with the rules applicable to those Practices and sanctions;
- (b) that they have not engaged in any Prohibited Practice as set forth herein;
- (c) that they have not misrepresented or concealed any material facts during the procurement or contract negotiation processes or during the performance of the contract;
- (d) that neither they nor their agents, personnel, sub-contractors, sub-consultants directors, officers or principal shareholders have been declared ineligible to be awarded a contract by the Bank or by another International Financial Institution (IFI) with which the Bank may have entered into an agreement for the mutual enforcement of sanctions or have been convicted of an offense involving a Prohibited Practice;
- (e) that none of their directors, officers or principal shareholders has been a director, officer or principal shareholder of any other company or entity that has been declared ineligible to be awarded a contract by the Bank or by another International Financial Institution (IFI) with which the Bank may have entered an agreement for the mutual enforcement of sanctions, or has been convicted of a crime involving a Prohibited Practice;
- (f) that all commissions, agents' fees, facilitating payments or revenue-sharing agreements related to the Bank-financed activities have been disclosed;
- (g) that they acknowledge that the breach of any of these representations may constitute a basis for the adoption by the Bank of one or more of the measures set forth in Clause 3.1 (b).

Section X. Contract Forms

Letter of Acceptance

[letterhead paper of the Purchaser]

[date]

To: *[name and address of the Supplier]*

Subject: **Notification of Award Contract No.** *[insert number]*

This is to notify you that your Bid dated *[insert date]* for execution of the *[insert name of the contract and identification number, as given in the SCC]* for the Accepted Contract Amount of *[insert amount in words] ([insert amount in numbers])*, as corrected and modified in accordance with the Instructions to Bidders is hereby accepted by our Agency.

You are requested to furnish the Performance Security within 28 days in accordance with the Conditions of Contract, using for that purpose the of the Performance Security Form included in Section X, Contract Forms, of the Bidding Document.

Authorized Signature: _____

Name and Title of Signatory: _____

Name of Agency: _____

Attachment: Contract Agreement

Contract Agreement

[The successful Bidder shall fill in this form in accordance with the instructions indicated]

THIS CONTRACT AGREEMENT is made

the *[insert: **number**]* day of *[insert: **month**], [insert: **year**]*.

BETWEEN

1. *[insert complete name of Purchaser]*, a *[insert description of type of legal entity, for example, an agency of the Ministry of of the Government of { insert name of Country of Purchaser }, or corporation incorporated under the laws of { insert name of Country of Purchaser }]* and having its principal place of business at *[insert address of Purchaser]* (hereinafter called “the Purchaser”), and
2. *[insert name of Supplier]*, a corporation incorporated under the laws of *[insert: country of Supplier]* and having its principal place of business at *[insert: address of Supplier]* (hereinafter called “the Supplier”).

WHEREAS the Purchaser invited bids for certain Goods and ancillary services, viz., *[insert brief description of Goods and Services]* and has accepted a Bid by the Supplier for the supply of those Goods and Services in the sum of *[insert Contract Price in words and figures, expressed in the Contract currency(ies)]* (hereinafter called “the Contract Price”).

NOW THIS AGREEMENT WITNESSETH AS FOLLOWS:

1. *In this Agreement words and expressions shall have the same meanings as are respectively assigned to them in the Conditions of Contract referred to.*
2. *The following documents shall constitute the Contract between the Purchaser and the Supplier, and each shall be read and construed as an integral part of the Contract:*
 - (a) This Contract Agreement
 - (b) Special Conditions of Contract
 - (c) General Conditions of Contract
 - (d) Technical Requirements (including Schedule of Requirements and Technical Specifications)
 - (e) The Supplier’s Bid and original Price Schedules
 - (f) The Purchaser’s Notification of Award
 - (g) *[Add here any other document(s)]*
3. This Contract shall prevail over all other Contract documents. In the event of any discrepancy or inconsistency within the Contract documents, then the documents shall prevail in the order listed above.
4. In consideration of the payments to be made by the Purchaser to the Supplier as hereinafter mentioned, the Supplier hereby covenants with the Purchaser to provide the Goods and Services and to remedy defects therein in conformity in all respects with the provisions of the Contract.

5. The Purchaser hereby covenants to pay the Supplier in consideration of the provision of the Goods and Services and the remedying of defects therein, the Contract Price or such other sum as may become payable under the provisions of the Contract at the times and in the manner prescribed by the Contract.

IN WITNESS whereof the parties hereto have caused this Agreement to be executed in accordance with the laws of *[insert the name of the Contract governing law country]* on the day, month and year indicated above.

For and on behalf of the Purchaser

Signed: *[insert signature]*

in the capacity of *[insert title or other appropriate designation]*

in the presence of *[insert identification of official witness]*

For and on behalf of the Supplier

Signed: *[insert signature of authorized representative(s) of the Supplier]*

in the capacity of *[insert title or other appropriate designation]*

in the presence of *[insert identification of official witness]*

Performance Security
(Bank Guarantee)

[The bank, as requested by the successful Bidder, shall fill in this form in accordance with the instructions indicated]

[Guarantor letterhead or SWIFT identifier code]

Beneficiary: *[insert name and Address of Purchaser]*

Date: *[Insert date of issue]*

PERFORMANCE GUARANTEE No.: *[Insert guarantee reference number]*

Guarantor: *[Insert name and address of place of issue, unless indicated in the letterhead]*

We have been informed that *[insert name of Supplier, which in the case of a joint venture shall be the name of the joint venture]* (hereinafter called "the Applicant") has entered into Contract No. *[insert reference number of the contract]* dated *[insert date]* with the Beneficiary, for the supply of *[insert name of contract and brief description of Goods and related Services]* (hereinafter called "the Contract").

Furthermore, we understand that, according to the conditions of the Contract, a performance guarantee is required.

At the request of the Applicant, we as Guarantor, hereby irrevocably undertake to pay the Beneficiary any sum or sums not exceeding in total an amount of *[insert amount in words]* (*[insert amount in numbers]*),¹ such sum being payable in the types and proportions of currencies in which the Contract Price is payable, upon receipt by us of the Beneficiary's complying demand supported by the Beneficiary's statement, whether in the demand itself or in a separate signed document accompanying or identifying the demand, stating that the Applicant is in breach of its obligation(s) under the Contract, without the Beneficiary needing to prove or to show grounds for your demand or the sum specified therein.

This guarantee shall expire, no later than the *[insert date]*², and any demand for payment under it must be received by us at this office indicated above on or before that date.

This guarantee is subject to the Uniform Rules for Demand Guarantees (URDG) 2010 Revision, ICC Publication No. 758, except that the supporting statement under Article 15(a) is hereby excluded*.

[signature(s)]

Note:

*Note: * [Information for the Executing Agency: Article 15 (a) states: "Requirements for Demand: (a) A demand under the guarantee shall be supported by such other documents as the guarantee specifies, and in any event by a statement, by the beneficiary, indicating in what respect the applicant is in breach of its obligations under the underlying relationship. This statement may be in the demand or in a separate document accompanying or identifying the demand.]*

¹ *The Guarantor shall insert an amount representing the percentage of the Accepted Contract Amount specified in the Letter of Acceptance, and denominated either in the currency(ies) of the Contract or a freely convertible currency acceptable to the Beneficiary.*

² *Insert the date twenty-eight days after the expected completion date as described in GC Clause 11.9. The Purchaser should note that in the event of an extension of this date for completion of the Contract, the Purchaser would need to request an extension of this guarantee from the Guarantor. Such request must be in writing and must be made prior to the expiration date established in the guarantee. In preparing this guarantee, the Purchaser might consider adding the following text to the form, at the end of the penultimate paragraph: "The Guarantor agrees to a one-time extension of this guarantee for a period not to exceed [six months][one year], in response to the Beneficiary's written request for such extension, such request to be presented to the Guarantor before the expiry of the guarantee."*

Advance Payment Security

[Guarantor letterhead or SWIFT identifier code]

Beneficiary: *[Insert name and Address of Purchaser]*

Date: *[Insert date of issue]*

ADVANCE PAYMENT GUARANTEE No.: *[Insert guarantee reference number]*

Guarantor: *[Insert name and address of place of issue, unless indicated in the letterhead]*

We have been informed that *[insert name of Supplier, which in the case of a joint venture shall be the name of the joint venture]* (hereinafter called "the Applicant") has entered into Contract No. *[insert reference number of the contract]* dated *[insert date]* with the Beneficiary, for the execution of *[insert name of contract and brief description of Goods and related Services]* (hereinafter called "the Contract").

Furthermore, we understand that, according to the conditions of the Contract, an advance payment in the sum *[insert amount in words]* (*[insert amount in figures]*) is to be made against an advance payment guarantee.

At the request of the Applicant, we as Guarantor, hereby irrevocably undertake to pay the Beneficiary any sum or sums not exceeding in total an amount of (*[insert amount in figures]*) *[insert amount in words]*¹ upon receipt by us of the Beneficiary's complying demand supported by the Beneficiary's statement, whether in the demand itself or in a separate signed document accompanying or identifying the demand, stating either that the Applicant:

- (a) has used the advance payment for purposes other than toward delivery of Goods; or
- (b) has failed to repay the advance payment in accordance with the Contract conditions, specifying the amount which the Applicant has failed to repay.

A demand under this guarantee may be presented as from the presentation to the Guarantor of a certificate from the Beneficiary's bank stating that the advance payment referred to above has been credited to the Applicant on its account number *[insert number]* at *[insert name and address of Applicant's bank]*.

The maximum amount of this guarantee shall be progressively reduced by the amount of the advance payment repaid by the Applicant as specified in copies of interim statements or payment certificates which shall be presented to us. This guarantee shall expire, at the latest, upon our receipt of a copy of the interim payment certificate indicating that ninety (90) percent of the Accepted Contract Amount, has been certified for payment, or on the *[insert date]*, whichever is earlier. Consequently, any demand for payment under this guarantee must be received by us at this office on or before that date.

This guarantee is subject to the Uniform Rules for Demand Guarantees (URDG) 2010 Revision, ICC Publication No.758, except that the supporting statement under Article 15(a) is hereby excluded*.

[signature(s)]

*Note: *[Information for the Executing Agency: Article 15 (a) states: "Requirements for Demand: (a) A demand under the guarantee shall be supported by such other documents as the guarantee specifies, and in any event by a statement, by the beneficiary, indicating in what respect the applicant is in breach of its obligations under the underlying relationship. This statement may be in the demand or in a separate document accompanying or identifying the demand.]*

SAMPLE FORMAT: Invitation for Bids

¹The Guarantor shall insert an amount representing the amount of the advance payment and denominated either in the currency(ies) of the advance payment as specified in the Contract, or in a freely convertible currency acceptable to the Purchaser.

[insert: name of Country]

[insert: name of Project]

[insert: loan / credit number]

[insert: IFB Title]

[insert: IFB Number]

1. This Invitation for Bids follows the General Procurement Notice for this Project that appeared in *Development Business*, issue no. *[insert number]* of *[insert date]*⁶.
2. The *[insert name of Borrower]* *[has received/has applied for/intends to apply for]* a *[financing]* from the Inter-American Development Bank toward the cost of *[insert name of Project]*, and it intends to apply part of the proceeds of this *financing* to payments under the Contract for *[insert name/no. of Contract]*⁷.
3. The *[insert name of Implementing Agency]* now invites sealed bids from eligible and qualified bidders for *[insert brief description of the Goods to be procured]*^{8,9}.
4. Bidding will be conducted through the International Competitive Bidding (ICB) procedures specified in the Inter-American Development Bank's Policies for the Procurement of Works and Goods financed by the Inter-American Development Bank, and is open to all bidders from Eligible Source Countries as defined in the Policies¹⁰.
5. Interested eligible bidders may obtain further information from *[insert name of Agency; insert name and e-mail of officer in charge]* and inspect the Bidding Documents at the address given below *[state address at end of this IFB]* from *[insert office hours]*.
6. Qualifications requirements include: *[insert a list of technical, financial, legal and other requirements]*. A margin of preference for certain goods manufactured domestically *[insert "shall" or "shall not", as appropriate]* be applied. Additional details are provided in the Bidding Documents.
7. A complete set of Bidding Documents in *[insert name of language: English, Spanish, French or Portuguese]* may be purchased by interested bidders on the submission of a written Application to the address below *[state address at the end of this ITB]* and upon payment of a non refundable fee¹¹ *[insert amount in local currency]* or in *[insert amount in specified convertible currency]*. The method of payment will be *[insert method of payment]*¹². The Bidding Documents will be sent by *[insert delivery procedure]*¹³.
8. Bids must be delivered to the address below *[state address at the end of this ITB]* at or before *[insert time and date]*. Electronic bidding will *[will not]* be permitted. Late bids will be rejected.

⁶ Day, month, year; for example, 31 January 1996.

⁷ *[Insert if applicable: "This contract will be jointly financed by [insert name of co financing agency]. Bidding will be governed by the Inter-American Development Bank's eligibility rules and procedures."]*

⁸ *A brief description of the type(s) of Goods or Works should be provided, including quantities, location of Project, and other information necessary to enable potential bidders to decide whether or not to respond to the Invitation. Bidding Documents may require bidders to have specific experience or capabilities; such requirements should also be included in this paragraph.*

⁹ *[Insert: "the delivery/construction period is [insert no. of days/months/years or dates"].*

¹⁰ *Occasionally, contracts may be financed out of special funds that would further restrict eligibility to a particular group of member countries. When this is the case, it should be mentioned in this paragraph. Also indicate any margin of preference that may be granted as specified in the Loan Contract and set forth in the Bidding Documents.*

¹¹ *The fee, should defray the printing and mailing/shipping costs; it should not deter competition.*

¹² *For example, cashier's check, direct deposit to specified account number.*

¹³ *The delivery procedure is usually airmail for overseas delivery and surface mail or courier for local delivery, or by electronic means if electronic bidding is permitted. If urgency or security dictates, courier services may be required for overseas delivery.*

Bids will be opened in the presence of the bidders' representatives who choose to attend in person or on-line at the address below *[state address at end of this ITB]* at *[insert time and date]*. All bids must be accompanied by a *[insert "Bid Security" or "Bid-Securing Declaration," as appropriate]* of *[insert amount in local currency or minimum percentage of bid price in case of a Bid Security]* or an equivalent amount in a freely convertible currency¹⁴¹⁵.

9. The address(es) referred to above is(are): *[insert detailed address(es) including Name of the Implementing Agency, Office designation (room number), name of Officer, Street address, City (code), Country; insert electronic address if electronic bidding is permitted]*.

RE TENDERED

¹⁴ *The amount of Bid Security should be stated as a fixed amount or as a minimum percentage of the Bid Price. Alternatively, if a Bid Security or a Bid-Securing Declaration is not required (often the case in supply contracts), the paragraph should so state.*

¹⁵ *The office for Bid Opening may not necessarily be the same as that for inspection or issuance of documents or for Bid Submission. If they differ, each address must appear at the end of paragraph 7 and be numbered; as, for example, (1), (2), (3). The text in the paragraph would then refer to address (1), (2), etc. Only one office and its address may be specified for submission of bids, and this location should be as close as possible to the place where bids will be opened to shorten the time between Bid Submission and Bid Opening.*